

**Recall Notice: Model PW3360 series and Model PW9002
Risk of Electric Shock**

Dear Valued customers:

Thank you very much for your continued patronage.

We regret to inform you that a failure has been found in our products. When the following models are used with Model PW9002 Battery Set, the safety of the products may be reduced if Model PW9002 is installed in the wrong way.

Model PW3360-10, PW3360-11, PW3360-20, PW3360-21, PW3360-30, PW3360-31 Clamp On Power Logger
Model PW3360-91 Clamp On Power Logger Set

Please accept our deepest apologies for any trouble this may cause, and ask for your understanding and cooperation.

1. Description of Failure

- When Model 9002 is installed onto Model PW3360 series (hereinafter referred to as "Model PW3360"), the battery case must be installed together with the battery protector using the four screws. See Fig. 1 on the next page.
- If the battery case is installed without the blue battery protector, the screws used to secure the battery case can protrude into the lower case of Model PW3360, enabling one of the screws to come into contact with the voltage input terminal (Terminal N).
- If Model PW3360 is subsequently used with the screw in contact with the voltage input terminal (Terminal N), an electric shock may occur.
- Once the screw has protruded into the case of Model PW3360, a safe distance cannot be ensured even if the battery protector is later re-installed, potentially resulting in electric shock. To avoid electric shock, do not use the unit with the lower case in this state.

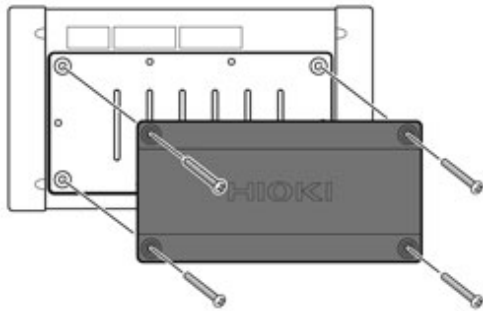

Fig. 1
Installing battery case

If the screw is fully tightened, the screw can come into contact with the voltage input terminal.



Fig. 2
With protector attached



Fig. 3
Without protector attached

2. Affected Products

- Model PW3360-10, PW3360-11, PW3360-20, PW3360-21, PW3360-30, PW3360-31 Clamp On Power Logger
- Model PW3360-91 Clamp On Power Logger Set
- Model PW9002 Battery Set

3. Action on Your Units

Since this failure can result in serious accidents, we kindly ask that you to take corrective action on your units. Your Hioki representative will contact you to make any arrangements and follow up with this issue.

Should you have any questions, please contact your Hioki distributor or sales subsidiary in your country. Once again, we sincerely apologize for the inconveniences caused.

Submitted by:

Approved by:

Hiroki Nagasawa

Yoshinori Sato

Hiroki Nagasawa
Technician
Quality Assurance Division
HIOKI E.E. CORPORATION
July 3, 2013

Yoshinori Sato
Manager
Quality Assurance Division