

RM9003

PRESS UNIT

Instruction Manual

EN

Oct. 2024 Revised edition 1
RM9003A961-01



HIOKI

www.hioki.com/



All regional contact information

HIOKI E.E. CORPORATION

81 Koizumi, Ueda, Nagano 386-1192 Japan

2402 EN

Edited and published by HIOKI E.E. CORPORATION

Printed in Japan

- Contents subject to change without notice.
- This document contains copyrighted content.
- It is prohibited to copy, reproduce, or modify the content of this document without permission.
- Company names, product names, etc. mentioned in this document are trademarks or registered trademarks of their respective companies.

Europe only

- EU declaration of conformity can be downloaded from our website.
- Contact in Europe: HIOKI EUROPE GmbH
Helfmann-Park 2, 65760 Eschborn, Germany hioki@hioki.eu

Introduction

Thank you for choosing the Hioki RM9003 Press Unit. Preserve this manual carefully and keep it handy to make full use of this device for a long time. Familiarize yourself with the RM2610 Electrode Resistance Measurement System Instruction Manual and the separate document entitled “Operating Precautions” before using the device.

Product registration

Register your product in order to receive important product information.
<https://www.hioki.com/global/support/myhioki/registration/>



The latest edition of the instruction manual

The contents of this manual are subject to change, for example as a result of product improvements or changes to specifications. The latest edition can be downloaded from Hioki’s website.
<https://www.hioki.com/global/support/download/>



Target audience

This manual has been written for use by individuals who use the product in question or who teach others to do so. It is assumed that the reader possesses basic electrical knowledge (equivalent to that of someone who graduated from the electrical program at a technical high school).

Safety notations

This manual classifies seriousness of risks and hazard levels as described below.

CAUTION	Indicates a potentially hazardous situation that may result in minor or moderate injury to the operator or damage to the device or malfunction.
IMPORTANT	Indicates information or content that is particularly important from the standpoint of operating or maintaining the device.
!	Indicates an action that must be performed.

Inspection

Check if there is any damage to the device occurred during storage or shipping and verify that device operates normally before using it.

Troubleshooting

If damage is suspected, read the “Before having your product repaired” section of the RM2610 Electrode Resistance Measurement System Instruction Manual before contacting your authorized Hioki distributor or reseller.

Cleaning

To clean the device, wipe it gently with a soft cloth.

IMPORTANT

Using solvent-containing detergents, such as benzene, alcohol, acetone, ether, ketone, thinners, and gasoline, or wiping the instrument with excessive force could cause deformation or discoloration.

Operating Precautions

Follow these precautions to ensure safe operation and to obtain the full benefits of the various functions.

CAUTION

- Do not place the device on an unstable or uneven surface. Doing so could cause the device to fall or turn over, causing bodily injury or damage to the device.

Specifications

Operating environment	Indoors, Pollution Degree 2, altitude up to 2000 m (6562 ft.)
Operating temperature and humidity	0°C to 40°C (32°F to 104°F), 80% RH or less (no condensation)
Storage temperature and humidity	0°C to 50°C (32°F to 122°F), 80% RH or less (no condensation)
Dimensions	Approx. 230W × 325D × 370H mm (9.06"W × 12.80"D × 14.57"H) (excluding protrusions) Distance from the probe contact position to the press unit support: approx. 144 mm (5.67")
Measuring object size	148 mm × 210 mm (A5 size) Thickness: up to 10 mm
Up/down stroke	Approx. 27.5 mm
Measurement stage	Resin graduated plate (10 mm, 5 mm) Center line in the middle
Mass	Approx. 8.5 kg (299.8 oz.)
Operation method	The test fixture is raised and lowered manually. The test fixture descends under its own weight until it comes into contact with the electrode sheet.
Lowering mechanism	The downward speed is cushioned by a damper. Time to lowered position: 1 s to 4 s (within the operating temperature range)
Tilt mechanism	This mechanism orients the tips of the test fixture’s probes so that they face the operator (in order to improve probe maintainability). The mechanism can be locked in the measurement orientation with the test fixture clamp knob.
Connecting and disconnecting the test fixture	The test fixture can be slid in and out. No set screws are used.
Locking the test fixture	Test fixture lock lever
Up/down lock function	<ul style="list-style-type: none"> • Raising the test fixture engages the lock. • A screw holds the lock mechanism in place (for use when transporting the system). • A slide disengages the lock function (to improve convenience during use).
Product warranty period	3 years
Accessories	Instruction manual Quick manual

Overview

The RM9003 Press Unit, which is designed exclusively for use with the Electrode Resistance Measurement System, is used after being affixed to the RM9004 Test Fixture. It serves to place the probes in contact with the measurement surface on the object under test (the electrode sheet). A tilt mechanism improves maintainability, while an up/down lock mechanism improves safety.

Part Names

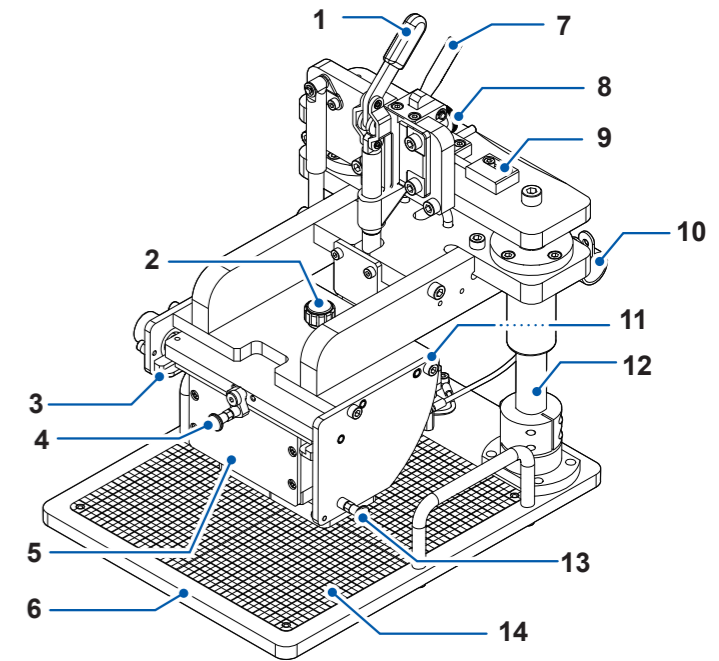

1	Up/down lever
2	Test fixture clamp knob
3	Test fixture insertion rail
4	Test fixture lock lever
5	RM9004 Test Fixture
6	Measurement stage
7	Lock release lever
8	Lock release lever clamp knob
9	Lock disable pin
10	Clamp
11	Serial number (The serial number consists of nine digits. The first two digits indicate the year of manufacture, while the second two digits indicate the month of manufacture. Do not remove this sticker because the number is important.)
12	Shaft (Do not touch as the shaft is coated with lubricating oil.)
13	Maintenance plunger
14	Graduated plate

Warranty Certificate

HIOKI

Model	Serial number	Warranty period
		Three (3) years from date of purchase (___ / ___ / ___)

Customer name: _____
Customer address: _____

Important

- Please retain this warranty certificate. Duplicates cannot be reissued.
- Complete the certificate with the model number, serial number, and date of purchase, along with your name and address. The personal information you provide on this form will only be used to provide repair service and information about Hioki products and services.

This document certifies that the product has been inspected and verified to conform to Hioki’s standards. Please contact the place of purchase in the event of a malfunction and provide this document, in which case Hioki will repair or replace the product subject to the warranty terms described below.

Warranty terms

- The product is guaranteed to operate properly during the warranty period (three [3] years from the date of purchase). If the date of purchase is unknown, the warranty period is defined as three (3) years from the date (month and year) of manufacture (as indicated by the first four digits of the serial number in YYYYMM format).
- If the product came with an AC adapter, the adapter is warranted for one (1) year from the date of purchase.
- The accuracy of measured values and other data generated by the product is guaranteed as described in the product specifications.
- In the event that the product or AC adapter malfunctions during its respective warranty period due to a defect of workmanship or materials, Hioki will repair or replace the product or AC adapter free of charge.
- The following malfunctions and issues are not covered by the warranty and as such are not subject to free repair or replacement:
 - Malfunctions or damage of consumables, parts with a defined service life, etc.
 - Malfunctions or damage of connectors, cables, etc.
 - Malfunctions or damage caused by shipment, dropping, relocation, etc., after purchase of the product
 - Malfunctions or damage caused by inappropriate handling that violates information found in the instruction manual or on precautionary labeling on the product itself
 - Malfunctions or damage caused by a failure to perform maintenance or inspections as required by law or recommended in the instruction manual
 - Malfunctions or damage caused by fire, storms or flooding, earthquakes, lightning, power anomalies (involving voltage, frequency, etc.), war or unrest, contamination with radiation, or other acts of God
 - Damage that is limited to the product’s appearance (cosmetic blemishes, deformation of enclosure shape, fading of color, etc.)
 - Other malfunctions or damage for which Hioki is not responsible
- The warranty will be considered invalidated in the following circumstances, in which case Hioki will be unable to perform service such as repair or calibration:
 - If the product has been repaired or modified by a company, entity, or individual other than Hioki
 - If the product has been embedded in another piece of equipment for use in a special application (aerospace, nuclear power, medical use, vehicle control, etc.) without Hioki’s having received prior notice
- If you experience a loss caused by use of the product and Hioki determines that it is responsible for the underlying issue, Hioki will provide compensation in an amount not to exceed the purchase price, with the following exceptions:
 - Secondary damage arising from damage to a measured device or component that was caused by use of the product
 - Damage arising from measurement results provided by the product
 - Damage to a device other than the product that was sustained when connecting the device to the product (including via network connections)
- Hioki reserves the right to decline to perform repair, calibration, or other service for products for which a certain amount of time has passed since their manufacture, products whose parts have been discontinued, and products that cannot be repaired due to unforeseen circumstances.

HIOKI E.E. CORPORATION
<http://www.hioki.com>

18-07 EN-3

Assembly (RM9003, RM9004, RM9005)

CAUTION

- To avoid equipment damage, turn off the RM2611 Electrode Resistance Meter before connecting or disconnecting the RM9005 Connection Cable.

IMPORTANT

The device ships with the up/down lever locked with the lock release lever clamp knob. Loosen the knob before using the device for the first time.

- Place the RM9003 Press Unit's up/down lever in the raised position.**
- Slide the RM9004 Test Fixture into position along the RM9003 Press Unit's test fixture insertion rails.**
Push the test fixture toward the rear until it won't go any further.
- Pull the test fixture lock lever toward you and downward and then let go to lock.**
The RM9004 Test Fixture will lock in place.
- Connect the grounding cable on the rear of the RM9003 Press Unit to the ground terminal on the RM9004 Test Fixture.**
- Connect the connector on the RM9004 (the female side) and connector on the RM2611 (the male side) using the RM9005 Connection Cable and screws that hold it in place.**
- Secure the RM9005 Connection Cable in place with the cable clamp.**

There are screws for attaching the cable clamp on the left and right sides of the RM9003 Press Unit. Choose the appropriate side based on the position of the device.

IMPORTANT

- When connecting the RM9005 Connection Cable, insert the cable into the connector firmly and tighten it in place with screws. If the screws loosen, the resulting poor contact could cause a measurement error.
- Exercise care not to lose the test fixture case's mounting screws, which you will need in order to store the RM9004 Test Fixture during transport.

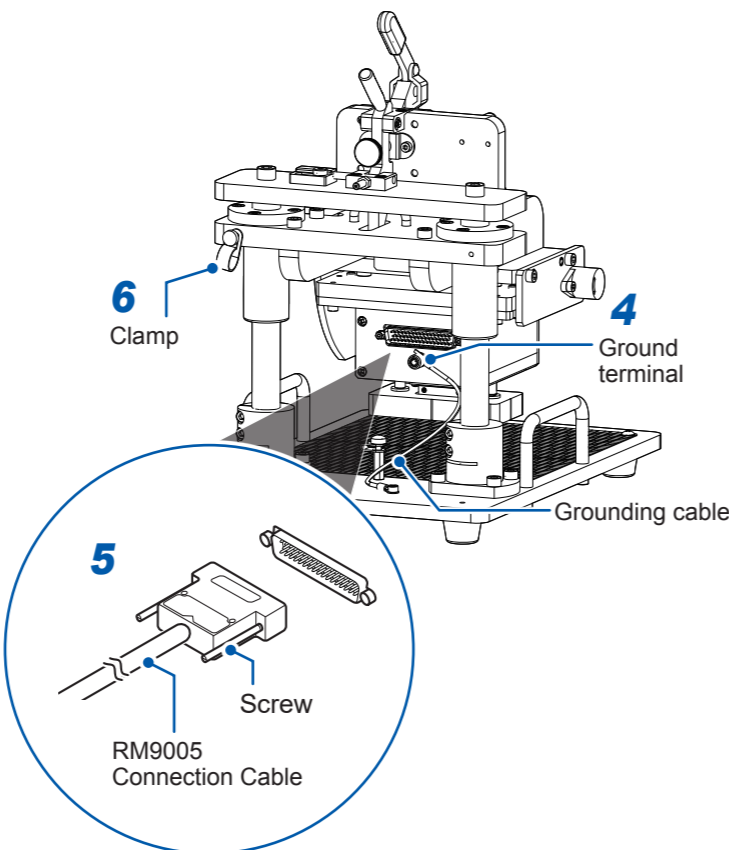
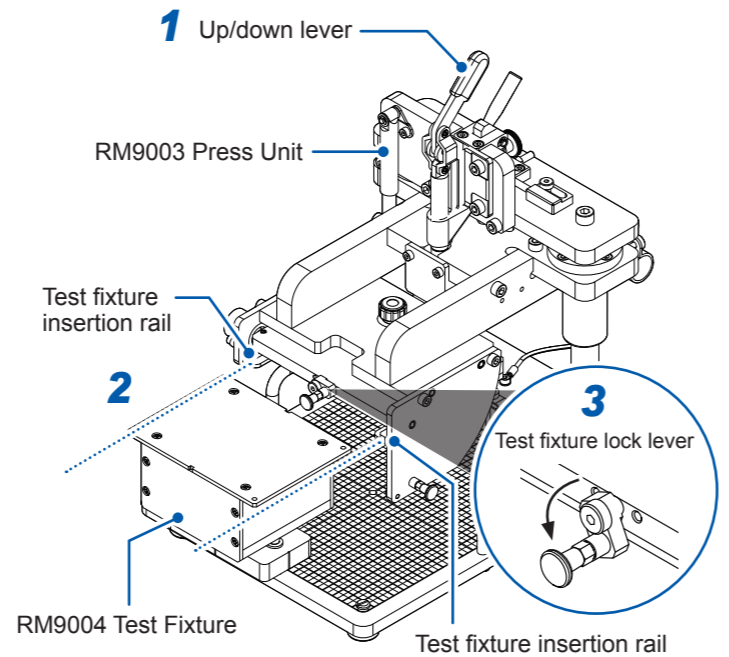

Basic Operation

IMPORTANT

- Exercise caution not to pinch your fingers or other body parts when lowering the RM9004 Test Fixture.
- Do not touch the tips of the probes when handling the electrode sheet.

- Place an electrode sheet on the measurement stage.**
The probes will make contact with the bold graduated marks.
- Pull the up/down lever toward you and down while pulling the lock release lever toward you.**
The RM9004 Test Fixture will move downward under its own weight.
- Once the RM9004 Test Fixture is fully lowered, start measurement from the main screen of RM2612 Resistance Calculation Software.**
See the RM2610 Electrode Resistance Measurement System Instruction Manual
- Once measurement completes, raise the up/down lever.**
- Remove the electrode sheet from the measurement stage after verifying that the RM9004 Test Fixture is fully raised.**

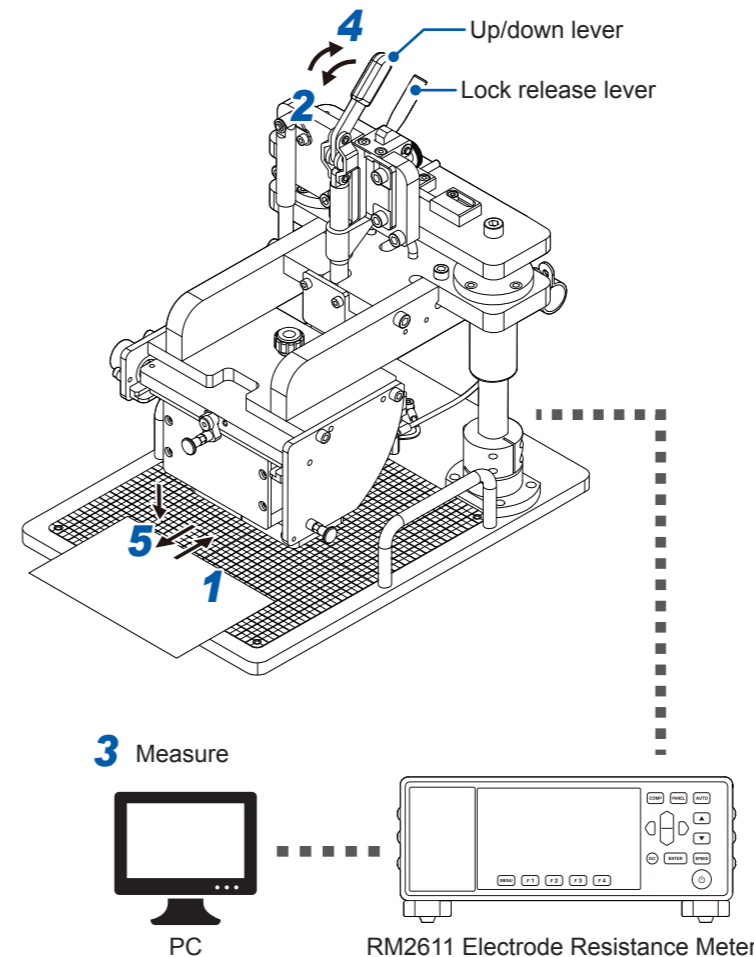

Precautions when transporting the device

Be sure to follow these precautions.

- To avoid damage to the device, remove the RM9004 Test Fixture and RM9005 Connection Cable from the device. Additionally, use the packaging in which the device was packed when you purchased it, and be sure to double-box it. Hioki cannot guarantee that the device will not be damaged during transport.
- Attach a description of the issue when sending out your device for repair.
- Raise the up/down lever and then tighten the lock release lever clamp knob to ensure that the press unit does not move up or down during transport.

