

Identification of PMSM Parameters with the Power Analyzer PW6001

This technical document provides a simple method for identifying motor parameters(for example, L_d, L_q , and K_e), which must be determined in order to implement vector control of permanent magnet synchronous motors (PMSMs), using Hioki's Power Analyzer PW6001.

1 Identification Principle

The PMSM voltage equation expressed on the d - q coordinate axis can be given as follows based on the following assumptions¹⁾:

- i) The spatial distribution of magnetic flux in the spaces between the stators and rotors takes the form of a sine wave aligned with the gap.
- ii) The harmonic components of voltage and current can be ignored.
- iii) The core loss can be ignored.

$$\begin{bmatrix} v_d \\ v_q \end{bmatrix} = \begin{bmatrix} R + pL_d & -\omega L_q \\ \omega L_d & R + pL_q \end{bmatrix} \begin{bmatrix} i_d \\ i_q \end{bmatrix} + \begin{bmatrix} 0 \\ \omega\phi_a \end{bmatrix} \quad (1)$$

where v_d and v_q represent the d -axis and q -axis components of each phase's armature voltage; i_d and i_q , the d -axis and q -axis components of each phase's armature current; R , each phase's armature resistance; p , the differential operator(d/dt); L_d and L_q , the self-inductance of the d -axis and q -axis; ω , the turning angle(electrical angle) velocity; and $\phi_a(= K_e)$, the permanent magnet's armature flux linkage RMS value(induced voltage constant).

Assuming a steady state (i.e., ignoring time-derivative terms), expressing Eq.(1) as a vector diagram of the d - and q -axes yields Fig. 1. In the figure, v_1 and i_1 represent the fundamental wave component of the phase voltage and phase current, respectively, while θ_v and θ_i represent the fundamental wave phase angle of the phase voltage and phase current, respectively. Based on Fig. 1, the voltage equations in the d -axis and q -axis

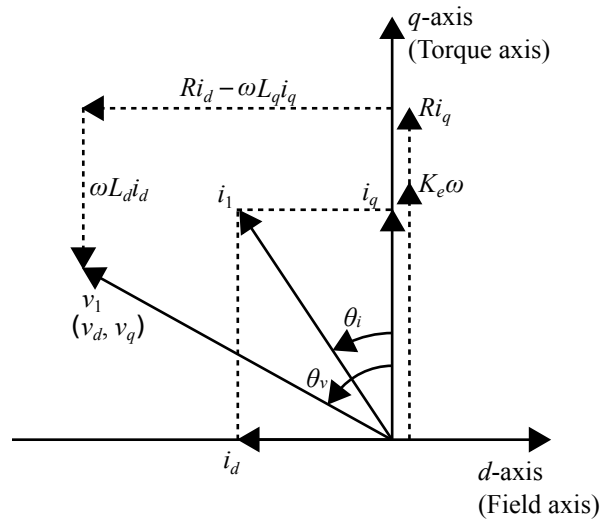

Fig. 1: PMSM Vector Diagram.

directions are:

$$K_e\omega + Ri_q = v_q - \omega L_d i_d \quad (2)$$

$$v_d = Ri_d - \omega L_q i_q. \quad (3)$$

Solving those equations for L_d and L_q yields the following:

$$L_d = \frac{v_q - K_e\omega - Ri_q}{\omega i_d} \quad (4)$$

$$L_q = \frac{Ri_d - v_d}{\omega i_q}. \quad (5)$$

2 Identification Procedure

2.1 Measurement of the Phase Armature Resistance R

Measure the phase armature resistance R beforehand using a resistance meter or other appropriate instrument.

2.2 Phase Zero-adjustment and Identification of the Induced Voltage Constant K_e

After placing the motor terminals of the PMSM being analyzed in the open state ($i_d = i_q = 0$), connect the motor terminals to the “CH 1”, “CH 2”, and “CH 3” voltage inputs on the PW6001. Then connect the encoder’s A-phase pulse output to “CH B”, the B-phase pulse output to “CH C”, and the Z-phase pulse (origin signal) output to “CH D”(Fig. 2).

Configure the PW6001 by setting the motor analysis operating mode to “Single”, the measurement parameter to “Torque Speed Direction Origin”, and “CH B” input to “Pulse”. Then set the wiring for “CH 1”, “CH 2”, and “CH 3” to “3P3W3M”, the synchronization source to “Ext1”, and Δ conversion to “ON”. Setting the synchronization source to “Ext1” allows the voltage and current phase angles to be measured using the inputted encoder pulse as the reference, and setting Δ conversion to “ON” allows the line voltage to be converted to, and measured as, a phase voltage.

Operate the motor from the load side in this state to generate an induced voltage and perform phase zero-adjustment on the PW6001. This step will ensure that θ_v and θ_i represent phase angles (in other words, electrical angles) based on the phase of the induced voltage generated along the q -axis.

At this time, the induced voltage v_q will equal v_1 , so that Eq.(4) can be rewritten as follows, enabling identification of K_e :

$$K_e = \frac{v_q}{\omega} = \frac{v_1}{2\pi f_1} \quad (6)$$

where $f_1 (= \omega/2\pi)$ represents the frequency of the phase voltage’s fundamental wave.

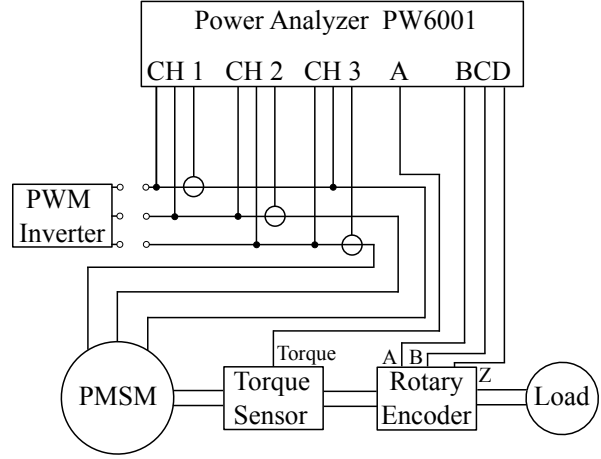

Fig. 2: Wiring for Phase Zero-adjustment and Induced Voltage Constant K_e Identification.

2.3 Identification of Motor Parameters L_d and L_q with User-defined Functions

The self-inductance of the d - and q -axes (L_d and L_q) can be identified using the value of R measured in Section 2.1 and the value of K_e identified in Section 2.2. Connect the drive inverter’s output to the motor terminals that were placed in the open state in Section 2.2 and operate the motor (Fig. 3). The following conditions will obtain based on Fig. 1, and these can be programmed as user-defined functions (UDFs) along with Eq.(4) and (5) to allow L_d and L_q to be easily identified while monitoring $v_d, v_q, i_d,$ and i_q :

$$v_d = -v_1 \sin \theta_v \quad (7)$$

$$v_q = v_1 \cos \theta_v \quad (8)$$

$$i_d = -i_1 \sin \theta_i \quad (9)$$

$$i_q = i_1 \cos \theta_i \quad (10)$$

A specific set of example settings follows. First, set UDF₁₋₄ to $v_d, v_q, i_d,$ and $i_q,$ respectively:

$$\text{UDF}_1 = -U_{\text{fnd1}} \cdot \sin \theta_{U1}$$

$$\text{UDF}_2 = U_{\text{fnd1}} \cdot \cos \theta_{U1}$$

$$\text{UDF}_3 = -I_{\text{fnd1}} \cdot \sin \theta_{I1}$$

$$\text{UDF}_4 = I_{\text{fnd1}} \cdot \cos \theta_{I1}$$

where $U_{\text{fnd1}}, I_{\text{fnd1}}, \theta_{U1},$ and θ_{I1} represent the basic measurement parameters for “CH 1” on the PW6001, indicating the fundamental wave component of the voltage

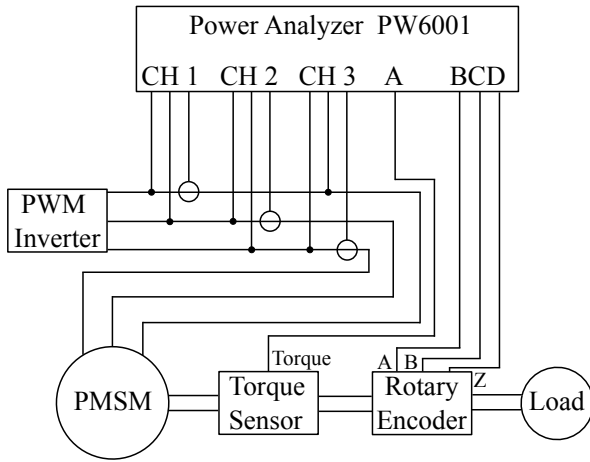

Fig. 3: Wiring Used to Identify the Motor Parameters L_d, L_q .

and current RMS values along with the voltage and current phase angles as follows:

$$\begin{aligned} U_{\text{fnd1}} &= v_1 \\ I_{\text{fnd1}} &= i_1 \\ \theta_{U1} &= \theta_v \\ \theta_{I1} &= \theta_i. \end{aligned}$$

Next, set L_d . Set UDF₅ to the second and third terms of the numerator in Eq.(4):

$$\text{UDF}_5 = (2\pi K_e) \cdot f_1 + R \cdot \text{UDF}_4.$$

Set UDF₆ to the denominator of Eq.(4):

$$\text{UDF}_6 = (2\pi) \cdot f_1 \cdot \text{UDF}_3.$$

Consequently, L_d can be calculated as follows:

$$\text{UDF}_7 = \text{UDF}_2 / \text{UDF}_6 - \text{UDF}_5 / \text{UDF}_6.$$

Finally, set L_q . Set UDF₈ to the numerator of Eq.(5):

$$\text{UDF}_8 = R \cdot \text{UDF}_3 - \text{UDF}_1.$$

The denominator of Eq.(5) can be written as follows:

$$\text{UDF}_9 = (2\pi) \cdot f_1 \cdot \text{UDF}_4.$$

Consequently, L_q can be calculated as follows:

$$\text{UDF}_{10} = \text{UDF}_8 / \text{UDF}_9.$$

Figs.4 to 6 depict the UDF screens on the Power Analyzer PW6001 when setting these UDF₁₋₁₀. In Fig. 5, $R = 0.9[\Omega]$ and $K_e = 32[\text{mV} \cdot \text{s}/\text{rad}]$, and the first term on the right side of the equation for UDF₅ is

$$2\pi K_e = 2 \cdot 3.14159 \cdot 32 \times 10^{-3} = 201.062\text{m}.$$

The value 0.9 has been set as the third term on the right side of the equation for UDF₅ and as the first term on the right side of the equation for UDF₈.

References

- 1) Shigeo Morimoto, Yoji Takeda, and Takao Hirasaka: "Method for Measuring a PM Motor's dq Equivalent Circuit Constants", IEEJ Transactions on Industry Applications, Vol.113-D (1993) No.11, pp.1330-1331 (in Japanese).

Document Revision History

| Date | Version | Changes |
|-----------|---------|----------------------------|
| Nov. 2015 | 1.0 | First edition |
| Mar. 2016 | 1.1 | Revision to correct errors |
| Sep. 2016 | 1.2 | Revision to correct errors |
| Oct. 2018 | 1.3 | Revision to correct errors |

| | | | | | | | | | | |
|---------------------|--|--|--|--|--|--|--|--|--|------------|
| 0000-00-00 00:00:00 | | | | | | | | | | Internal |
| | | | | | | | | | | USB |
| | | | | | | | | | | WIRING |
| | | | | | | | | | | CHANNEL |
| | | | | | | | | | | COMMON |
| | | | | | | | | | | EFFICIENCY |
| | | | | | | | | | | UDF |
| | | | | | | | | | | MOTOR |

| | | | | | | | | | |
|--------------------|-----|---|--------------------|---|-----|-----------------|-----|-----|-------|
| UDF ₁ = | neg | * | U _{find1} | * | sin | θ _{U1} | OFF | OFF | |
| MAX | | | Unit | | | | | | |
| UDF ₂ = | | * | U _{find1} | * | cos | θ _{U1} | OFF | OFF | |
| MAX | | | Unit | | | | | | |
| UDF ₃ = | neg | * | I _{find1} | * | sin | θ _{I1} | OFF | OFF | 1-4 |
| MAX | | | Unit | | | | | | 5-8 |
| UDF ₄ = | | * | I _{find1} | * | cos | θ _{I1} | OFF | OFF | 9-12 |
| MAX | | | Unit | | | | | | 13-16 |

Fig. 4: Example Settings for User-Defined Functions (UDF₁₋₄).

| | | | | | | | | | | |
|---------------------|--|--|--|--|--|--|--|--|--|------------|
| 0000-00-00 00:00:00 | | | | | | | | | | Internal |
| | | | | | | | | | | USB |
| | | | | | | | | | | WIRING |
| | | | | | | | | | | CHANNEL |
| | | | | | | | | | | COMMON |
| | | | | | | | | | | EFFICIENCY |
| | | | | | | | | | | UDF |
| | | | | | | | | | | MOTOR |

| | | | | | | | | | |
|--------------------|------------------|---|------------------|---|------------------|---|------------------|--|-------|
| UDF ₅ = | +201.062m | * | f ₁ | + | +0.90000 | * | UDF ₄ | | |
| MAX | | | Unit | | | | | | |
| UDF ₆ = | +6.28319 | * | f ₁ | * | UDF ₃ | | OFF | | |
| MAX | | | Unit | | | | | | |
| UDF ₇ = | UDF ₂ | / | UDF ₆ | - | UDF ₅ | / | UDF ₆ | | 1-4 |
| MAX | | | Unit | | | | | | 5-8 |
| UDF ₈ = | +0.90000 | * | UDF ₃ | - | UDF ₁ | | OFF | | 9-12 |
| MAX | | | Unit | | | | | | 13-16 |

Fig. 5: Example Settings for User-Defined Functions(UDF₅₋₈).

| | | | | | | | | | | |
|---------------------|--|--|--|--|--|--|--|--|--|------------|
| 0000-00-00 00:00:00 | | | | | | | | | | Internal |
| | | | | | | | | | | USB |
| | | | | | | | | | | WIRING |
| | | | | | | | | | | CHANNEL |
| | | | | | | | | | | COMMON |
| | | | | | | | | | | EFFICIENCY |
| | | | | | | | | | | UDF |
| | | | | | | | | | | MOTOR |

| | | | | | | | | | |
|---------------------|------------------|---|------------------|---|------------------|--|-----|--|-------|
| UDF ₉ = | +6.28319 | * | f ₁ | * | UDF ₄ | | OFF | | |
| MAX | | | Unit | | | | | | |
| UDF ₁₀ = | UDF ₈ | / | UDF ₉ | | OFF | | OFF | | |
| MAX | | | Unit | | | | | | |
| UDF ₁₁ = | OFF | | OFF | | OFF | | OFF | | 1-4 |
| MAX | | | Unit | | | | | | 5-8 |
| UDF ₁₂ = | OFF | | OFF | | OFF | | OFF | | 9-12 |
| MAX | | | Unit | | | | | | 13-16 |

Fig. 6: Example Settings for User-Defined Functions(UDF₉₋₁₂).