

Insulation Tester IR4053

Takeaki Miyazawa

Engineering Division 5, Engineering Department

Abstract—The Insulation Tester IR4053 is an insulation tester designed for use in the maintenance of solar power system equipment. This paper describes the product's features, architecture, and other characteristics.

I. INTRODUCTION

Due in part to rising awareness of environmental issues, increasingly serious power shortages, and Japan's national initiatives to promote use of solar power in recent years, there has been rapid growth in use of solar power systems, from small-scale residential setups to large-scale megasolar installations. These developments are driving growing demand for equipment maintenance.

To prevent accidents caused by faulty insulation during installation and regular inspections of solar power systems, it is necessary to check the state of insulation by measuring the insulation resistance at various points in the system. When using a standard insulation tester to accomplish this task, the technician must cut off power to the measurement target before measuring the insulation resistance. In the case of solar panels, insulation resistance must be measured while the system is at a dangerous voltage since electricity is always generated while the system is exposed to sunlight during the day. Consequently, technicians must exercise a high level of caution with regard to the hazard of electrical shock while measuring insulation resistance. In addition, it is sometimes not possible to obtain accurate resistance insulation values when a standard insulation tester is used to test a solar power system because the voltage produced by the solar panels affects the measurement results.

It was against this backdrop that Hioki developed the Insulation Tester IR4053 as an instrument that is able to safely and accurately measure the insulation resistance of solar panels.

II. OVERVIEW

A. Overview of the IR4053

The IR4053 is a portable digital insulation tester. Developed to be capable of measuring the insulation resistance of solar panels safely, accurately, and quickly, it is ideal for maintenance of solar power systems.

The instrument features a new photovoltaic resistance function designed specifically to measure the insulation resistance of solar panels. This function makes it possible to accurately measure insulation resistance free from the effects of the electricity being produced by the panel under



Appearance of the IR4053.

measurement. Furthermore, the instrument provides voltage measurement functionality for measuring voltages of up to 1000 V DC, a capability that is ideal for measuring the no-load voltage of solar panels.

In addition, the instrument provides ordinary insulation resistance measurement functionality (with five ranges) that complies with Japanese Industrial Standards (JIS) C1302, allowing measurement of the insulation resistance of equipment other than solar panels.

The IR4053 is available in two configurations: as the IR4053-10, which includes standard-type test leads, and as the IR4053-11, which includes switched test leads, for the Japanese domestic market.

B. Measurement of Solar Panel Insulation Resistance

The technical report JEM-TR228, *Maintenance and inspection guidelines for photovoltaic power generating systems up to 50 kW for low-voltage network* (Japanese), published by The Japan Electrical Manufacturers' Association, provides important information about the maintenance and inspection of solar power systems. The guidelines describe the measurement methods in addition to the maintenance and inspection items of small-scale solar power systems, and they recommend that the insulation resistance of relay terminal boxes (junction boxes and power

collection boxes) and power conditioning systems (PCSs) be measured as part of both the post-installation inspection and regular inspections.

Two methods are used to measure the insulation resistance of solar panels, and they differ in both safety and accuracy. Whichever method is used, all strings must be measured. To prepare for measurement, the junction box's output disconnect must be turned off to isolate it from the PCS and power collection box. In addition, all string switches must be turned off. Each of the two methods is described below.

1) *Method in which P and N are not short-circuited:* Fig. 1 illustrates a measurement method in which P (the positive electrode) and N (the negative electrode) are not short-circuited. The insulation resistance between P and E (ground) is measured, and then the insulation resistance between N and E is measured. This method is safer than the method in which P and N are short-circuited, which is described below. However, in some cases it is not possible to obtain an accurate insulation resistance value due to the effect of the voltage produced by the solar cell on insulation resistance measurement, which results from the deterioration of the solar panel's insulation.

2) *Method in which P and N are short-circuited:* Fig. 2 illustrates a measurement method in which P and N are short-circuited. A shorting switch is used to short-circuit P and N, and the insulation resistance between the output of the shorting switch and E is measured. While this method yields accurate insulation resistance values, it poses the risk of daytime electric shock, since that's when solar panels operate. In this way, an arc discharge could occur during work. In addition, abnormal heating may occur when P and N terminals of a faulty solar panel are short-circuited, posing a fire hazard.

3) *Example of the failure of the non-short-circuiting method to yield accurate measurements:* Fig. 3 and Fig. 4 illustrate measurement of the insulation resistance between P and E when the P terminal is grounded and when the N terminal is grounded, respectively.

When measuring the insulation resistance between P and E while the P terminal is grounded, as shown in Fig. 3, there is no route by which current produced by the solar panel can find its way to the insulation tester, enabling accurate measurement. However, when measuring the circuit with the N terminal grounded, as shown in Fig. 4, current produced by the solar panel can flow to the insulation tester. Since current from the instrument and current from the solar panel flow in the same direction and are added, the result is that the measured resistance value is less than the actual insulation resistance. By contrast, if the instrument is connected such that the direction of the insulation tester's current is opposite to that of the solar panel's current, the current values are subtracted, with the result that the indicated measured resistance value is larger than the actual

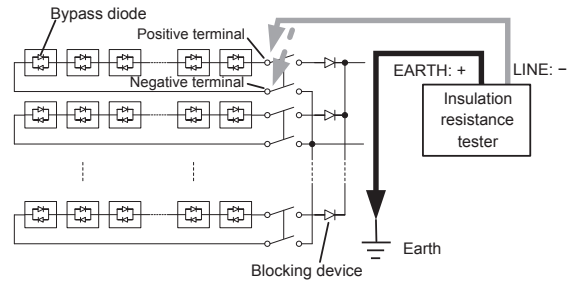

Fig. 1. Method in which P and N are not short-circuited.

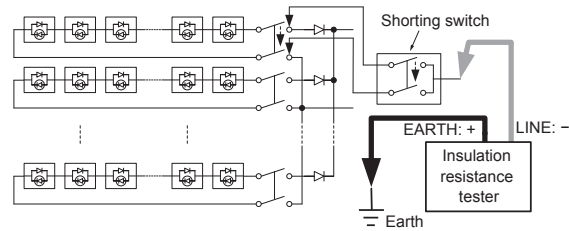

Fig. 2. Method in which P and N are short-circuited.

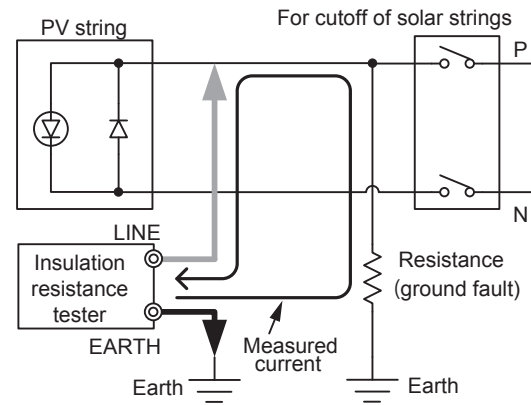

Fig. 3. P-E measurement diagram when P is grounded.

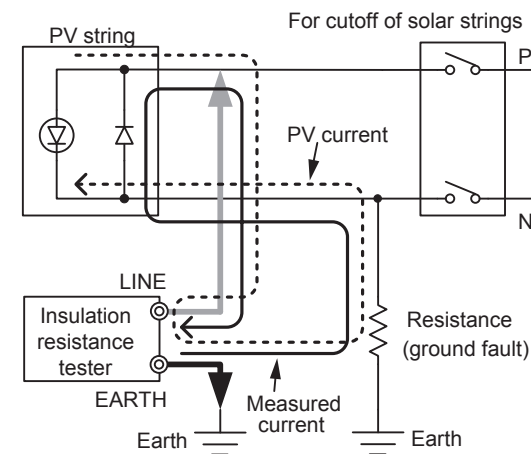

Fig. 4. P-E measurement diagram when N is grounded.

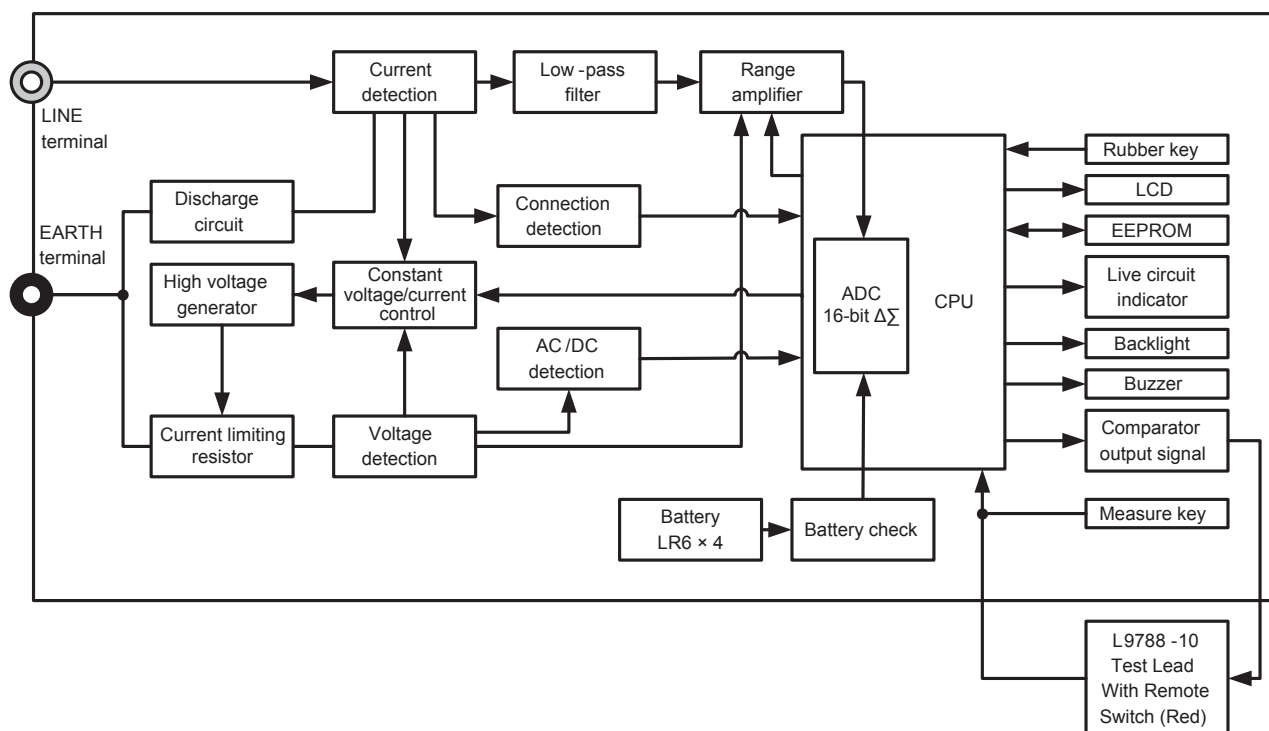

Fig. 5. Block diagram.

insulation resistance. The IR4053's photovoltaic resistance function is able to measure insulation resistance accurately without being affected by the current produced by the panel, even when using the method in which P and N are not short-circuited.

III. FUNCTIONS AND FEATURES

A. Photovoltaic Resistance Function

The IR4053's photovoltaic resistance function can make accurate measurements even when using the method in which P and N are not short-circuited. In addition, the function is safer than the method in which P and N are short-circuited, and the process can be performed more easily since there is no need to short the terminals. The applied voltage can be set to either 500 V or 1000 V.

Large-scale facilities such as megasolar installations require measurement of large numbers of strings, making it desirable to keep measurement times short so that work can be completed more quickly. Since the instrument displays the measured value within 4 seconds from the start of measurement when using the photovoltaic resistance function, the IR4053 is well suited to maintenance work at large-scale solar power installations.

B. Insulation Resistance Function

The IR4053 also provides an insulation resistance function with the same measurement performance as instruments in the previous IR4050 series, allowing its use

in standard insulation resistance measurement applications in addition to solar panel measurement applications. Five ranges (50 V, 125 V, 250 V, 500 V, and 1000 V) are available for selection depending on the specific application at hand, and measured values are displayed within 1 second of the start of measurement, ensuring fast measurement.

C. Voltage Measurement Up to 1000 V DC

Technicians measure no-load voltage during maintenance of solar power systems, and solar power systems operating at up to 1000 V are becoming increasingly common in Japan. The IR4053 provides a voltage function that can measure voltages of up to 1000 V DC, allowing its use in inspecting the no-load voltage of these 1000 V systems.

D. Negative Voltage Warning Function

The IR4053 also provides a negative voltage warning function that causes the screen to flash red if the voltage measurement function yields a negative voltage measured value. During system installation, technicians measure voltage in order to check the no-load voltage and wiring connections. If the P and N terminals are unintentionally connected backwards, a negative voltage value will be indicated; however, technicians sometimes overlook the negative indication and with it, the erroneous wiring. By using a flashing red screen to alert the operator to a negative voltage value, the IR4053 ensures that such wiring mistakes will not be overlooked.

Insulation Tester IR4053

E. Comparator Function

The IR4053's photovoltaic resistance function and insulation resistance function include a comparator function that generates comparative judgments relative to user-specified values. The instrument reports the judgment results by beeping and turning the screen red. Work efficiency can be further improved by using switched leads (a standard accessory of the IR4053-11), which incorporate an indicator that reports the results.

IV. ARCHITECTURE

A. Hardware

Fig. 5 provides an overall block diagram for the IR4053. The instrument shares circuitry associated with functionality such as insulation resistance measurement, voltage measurement, and power supply control as well as the construction of related hardware with the IR4050 series.

1) *AC/DC voltage measurement*: The basic circuit architecture with which AC/DC voltage measurement is implemented is the same as that used by the IR4050 series. The instrument automatically detects whether the input voltage is AC or DC. For DC voltage measurement, the maximum rated terminal-to-terminal voltage is 1000 V DC, allowing the instrument to be used to measure the no-load voltage of 1000 V solar power systems.

2) *Photovoltaic resistance measurement*: The basic architecture with which photovoltaic resistance measurement is implemented is the same as that used by the IR4050 series. During normal insulation measurement, no voltage is applied to the insulation tester because the measurement target's power supply is disconnected. During photovoltaic resistance measurement, a resistance is inserted into the circuit for current limiting purposes since the voltage produced by the solar panel may be applied to the insulation tester. After measurement starts, the solar panel's voltage and current are measured, and then a voltage is applied from the insulation tester before measuring the voltage and current again. Then the measured values for the solar panel's voltage and current are used along with the measured values for voltage and current obtained while applying the voltage from the insulation tester to the solar panel to calculate a resistance value from which the effects of the solar panel have been eliminated.

B. Characteristics

1) *Solar panel insulation resistance measurement*: Fig. 6 provides a test model. A resistance was connected between the solar panel's P and E terminals or N and E terminals in order to simulate a ground fault of the panel. TABLE I lists the specifications of the panel used in the test. To facilitate a comparison of insulation resistance values, the panel's insulation resistance was measured with the normal insulation resistance function as well as the photovoltaic resistance function. The insulation tester's measurement

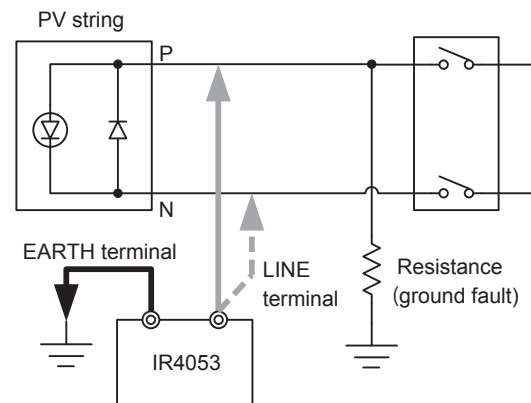

Fig. 6. Test model (P-E ground fault).

TABLE I. SOLAR PANEL (STRING) SPECIFICATIONS

Item	Specification
Connection type	15 in series
Nominal maximum output operating voltage	26.6 V
Nominal maximum output operating current	8.09 A
Nominal no-load voltage	33.2 V
Nominal short-circuit current	8.78 A
Maximum system voltage	600 V

voltage was 500 V. TABLE II lists the measurement results.

When making measurements using the photovoltaic resistance function, it is possible to verify that all measurements have yielded accurate values since the effects of the solar panel are eliminated by means of the calculations performed. By contrast, the normal insulation resistance function may not yield accurate measured values since the voltage produced by the solar panel affects the insulation tester.

V. CONCLUSION

The IR4053 resolves issues of accuracy and safety that have affected measurement of the insulation resistance of solar panels to date. In addition, the instrument's fast measurement times promise to boost the efficiency of maintenance work. Hioki hopes that the IR4053 will find use by many customers involved with the installation and maintenance of solar power systems.

Masahiro Nakazawa*1

*1 Engineering Division 5, Engineering Department

TABLE II. SOLAR PANEL INSULATION RESISTANCE MEASUREMENT RESULTS

Resistance values [MΩ]		Measurement location	Photovoltaic resistance function		Insulation function	
<i>P-E</i>	<i>N-E</i>		<i>Measured value [MΩ]</i>	<i>Error [%]</i>	<i>Measured value [MΩ]</i>	<i>Error [%]</i>
n/a	n/a	P-E	1170	n/a	1290	n/a
0.2	n/a		0.200	0.00	0.200	0.00
0.4	n/a		0.399	-0.25	0.400	0.00
1.0	n/a		1.000	0.00	0.998	-0.20
10.0	n/a		9.96	-0.40	9.91	-0.90
n/a	0.2		0.200	0.00	0.000	-100.00
n/a	0.4		0.399	-0.25	0.000	-100.00
n/a	1.0		0.995	-0.50	0.521	-47.90
n/a	10.0		9.97	-0.30	5.21	-47.90
n/a	n/a		N-E	> 2000	n/a	> 2000
0.2	n/a	0.201		0.50	2.260	1030.00
0.4	n/a	0.401		0.25	4.680	1070.00
1.0	n/a	1.000		0.00	11.2	1020.00
10.0	n/a	9.77		-2.30	10.5	5.00
n/a	0.2	0.199		-0.50	0.199	-0.50
n/a	0.4	0.399		-0.25	0.400	0.00
n/a	1.0	0.995		-0.50	0.999	-0.10
n/a	10.0	9.77		-2.30	10.00	0.00

