

Battery Impedance Meter BT4560

Akihiro Narusawa

Engineering Division 2, Engineering Department

Abstract—The Battery Impedance Meter BT4560 is an impedance meter that can measure batteries' internal impedance using an AC signal from 0.1 Hz to 1,050 Hz. Its distinguishing feature is its ability to measure large, increasingly low-impedance batteries with a high degree of precision. This paper describes the product's functionality, features, and architecture.

I. INTRODUCTION

Because lithium-ion batteries (see Fig. 1) are used in a wide range of products such as electric vehicles, hybrid vehicles, mobile phones, and portable music players, the market for them is expanding with each passing year. Lithium-ion batteries used in electric vehicles and hybrid vehicles must deliver the highest possible level of performance and quality. Internal resistance measurement is one method for evaluating the performance and quality of lithium-ion batteries, and resistance, which derives from the chemical reactions inside the batteries, conventionally has been measured using a method known as DC-IR measurement. This method involves measuring the internal resistance of a previously charged lithium-ion battery while discharging it by drawing a large current. However, it takes anywhere from several minutes to dozens of minutes to charge the battery being tested in advance, and the internal resistance measurement process itself requires a period ranging from dozens of minutes to about one hour to complete. As a result, there has been strong demand from operators for a solution that shortens measurement times. Internal resistance measurement at low frequencies (low-frequency AC-IR measurement) resolves this issue by enabling measurement times to be shortened to as little as 10 seconds.

Hioki developed the Battery Impedance Meter BT4560 to offer low-frequency AC-IR measurement as a new method for testing lithium-ion batteries.

II. DESIGN CONCEPT

The BT4560, which in effect proposes a new measurement method to use as an alternative to DC-IR measurement, was developed based on the concept of evaluating the reliability of lithium-ion batteries in just 10 seconds. Hioki saw large lithium-ion batteries—a market that has been growing at a remarkable rate in recent years—as the instrument's principal target.



Appearance of the BT4560

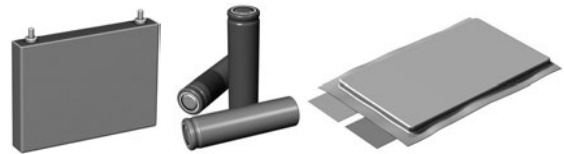
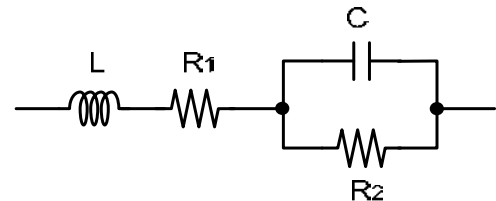

Fig. 1. Lithium-ion Batteries



L: Inductance
 R_1 : Electrolyte resistance
 R_2 : Charge transfer resistance
 C: Electric double layer capacitance

Fig. 2. Battery Equivalent Circuit

III. FUNCTIONS AND FEATURES

The BT4560 delivers the following functions and features:

1) Variable frequency

The BT4560 can perform impedance measurement at frequencies from 0.1 Hz to 1,050 Hz. In addition to electrolyte resistance, which can be measured by conventional battery testers that use a fixed frequency of 1 kHz (R_1 in Fig. 2), the instrument can measure charge transfer resistance using a low frequency of 1 Hz or less (R_2 in Fig. 2). Charge transfer resistance, which is caused by the movement of ions between the electrolyte and the battery's

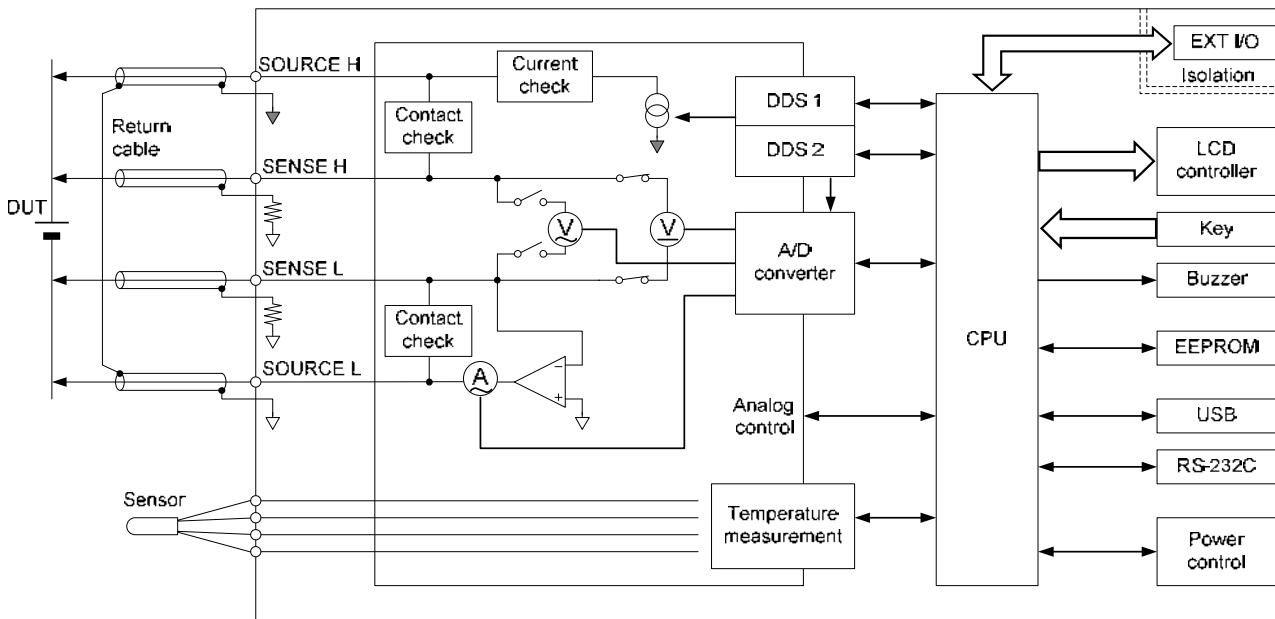

Fig. 3. Block Diagram

electrodes, serves as an important indicator in the evaluation of battery characteristics.

In addition, the BT4560 supports frequency sweep operation using computer-based application software, and it can generate Cole-Cole plots, which are used in battery evaluation.

2) High-precision measurement

The BT4560 delivers an improved S/N ratio by using a measurement current of up to 1.5 A. This approach improves the instrument's resistance to noise and enables vehicle batteries, whose internal resistance may be less than 1 m Ω , to be measured with a high degree of precision. The BT4560 provides a resolution of 10 μ V for DC voltage measurement along with accuracy of $\pm 0.0035\%$ rdg., exceeding performance of previous models.

3) More compact size

The conventional approach to measuring battery impedance consisted of a frequency response analyzer (FRA), potentiostat-galvanostat, and computer. By contrast, the BT4560 delivers a simple, compact architecture that enables the same measurements to be performed with a single instrument.

4) Measurement cable length

Thanks to zero-adjustment functionality and a circuit architecture that provides resistance to the effects of contact and wiring resistance, accuracy is guaranteed up to a measurement cable length of 4 m.

5) Temperature measurement function

Batteries' charge transfer resistance is susceptible to the effects of temperature. To manage the ambient air

temperature during resistance measurement, the BT4560 provides temperature measurement functionality using a platinum sensor.

6) Contact check

By monitoring contact resistance before and after measurement, the BT4560 can prevent measurement in which the probes are not in contact with the measurement target.

7) Sample delay

Batteries' response waveforms are distorted immediately after application of AC. To address this issue, the BT4560 lets the operator set a delay time from the time the AC is applied to the start of sampling.

8) Slope correction

Linear drift of the measurement signal caused by battery characteristics or the BT4560's input impedance can be corrected.

9) Prevention of charging or discharging during AC application

By keeping the application start and end phases of the measurement AC signal at 0°, the BT4560 prevents charging and discharging of the battery being measured.

IV. ARCHITECTURE

Fig. 3 provides an overall block diagram of the BT4560.

A. Analog Circuitry

1) Impedance measurement circuit

A sine-wave measurement current is generated by a

constant-current source and applied to the measurement target. At this time, the measurement current and voltage across the measurement target are measured, and the impedance value is calculated. The measurement current is measured by the current detection block. The voltage generated across the measurement target is measured by the voltage detection block as the voltage between the SENSE H terminal and the SENSE L terminal. The measurement current has been increased to a maximum of 1.5 A, compared to a maximum of 100 mA for previous models. The higher current improves the instrument's noise resistance and enables it to perform stable measurement of super-low impedance values of 1 m Ω or less.

In addition, use of the four-terminal-pair method reduces the effects of electromagnetic induction on the measurement current to yield more stable impedance measured values. Measurement flux caused by the measurement current can affect the detected voltage due to the effects of electromagnetic induction, compromising the stability of the impedance value being measured. Thanks to the use of a floating constant-current source, the measurement current that flows to the measurement target flows back to the BT4560's constant-current source via a return cable. This arrangement limits the magnetic flux caused by the measurement current.

2) DC voltage measurement circuit

The BT4560 has a DC voltage detection block that is separate from the voltage detection block used in impedance measurement for measuring battery voltages. DC voltage measurement accuracy has been improved to 0.0035% rdg., compared to 0.01% rdg. for previous models. By calibrating itself to maintain the measurement precision, the instrument corrects for the DC voltage measurement circuit's offset voltage and gain drift.

3) Measurement error detection

The BT4560 includes four types of measurement error detection: a contact check circuit, a constant-current error detection circuit, an overvoltage detection function, and a return cable disconnect detection function.

The contact check circuit acts to detect faulty contact that could impair measurement, for example an issue with the contact state or a measurement probe wire break. It detects the resistance value between the SOURCE H terminal and the SENSE H terminal as well as between the SOURCE L terminal and the SENSE L terminal.

The constant-current error detection circuit detects an error if the proper constant current does not flow to the measurement target due to increased resistance between the SOURCE H terminal and the SOURCE L terminal.

The overvoltage detection function detects connection of a battery that exceeds the instrument's rated voltage. The BT4560 can measure batteries of up to 5.1 V. If a battery that exceeds the rated voltage is connected, the function detects an error before measurement.

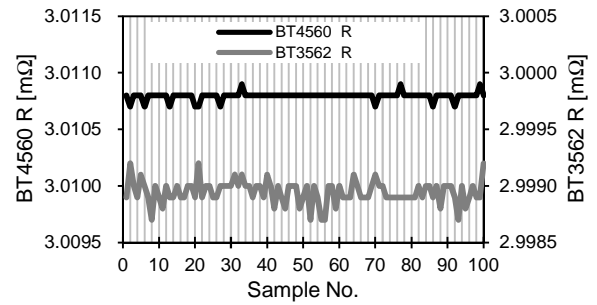

Fig. 4. R Repeatability During 3 m Ω Resistance Measurement

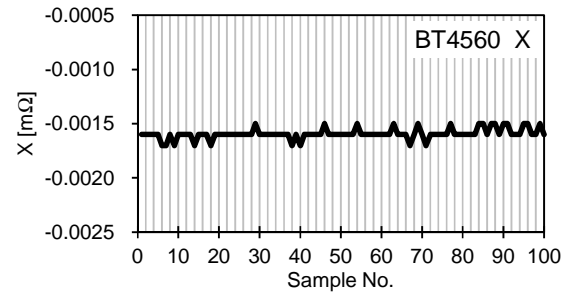

Fig. 5. X Repeatability During 3 m Ω Resistance Measurement

The return cable disconnect detection function detects when the CPU is not connected based on the measurement current calculation value.

B. Digital Circuitry

Reflecting considerations such as computation performance and power consumption, the BT4560 uses a 32-bit RISC CPU with on-chip ROM and RAM. In addition to control keys, the display, external I/O, and communications, the CPU controls the instrument's analog functionality, including DDS, A/D conversion, D/A conversion, and error signal processing.

The instrument uses DDS1 for measurement waveform output and DDS2 for the converter sampling clock. DDS2 generates a clock so that the sampling number remains constant regardless of the output waveform's frequency.

The instrument uses two A/D converters for current and voltage waveform measurement, and simultaneous sampling of current and voltage is controlled by the CPU. To implement simultaneous sampling, the BT4560's timing design takes into account various delays, for example in photocoupler control between the CPU and the A/D converters and in capturing data at the CPU's ports.

V. PERFORMANCE

A. Repeatability

Figs. 4 and 5 illustrate variability when repeating an impedance measurement 100 times.

Battery Impedance Meter BT4560

The measurement conditions were as follows:

- Measurement target: 3 mΩ resistor element
- Measurement range: 3 mΩ
- Sampling speed: SLOW
- (Measurement time: 128 ms)

Variability was limited to ±1 dgt. (0.1 μΩ) for both the R value (real portion) and X value (imaginary portion), indicating a high level of repeatability. Fig. 4 also presents variability when the same measurement was performed with the Battery HiTester BT3562, Hioki's previous model. With the exception of the measurement target calibration value, the same measurement conditions were used. Repeatability is an important consideration when performing shipping inspections of batteries, and the BT4560 delivers stability that is greater than or equal to that of previous models.

Fig. 6 illustrates variability in DC voltage measurement. Stability characterized by variability of ±1 dgt. (10 μV) is maintained during DC voltage measurement as well. The measurement voltage was 4.99 V, and the sampling speed was SLOW (measurement time: 1.0 sec.).

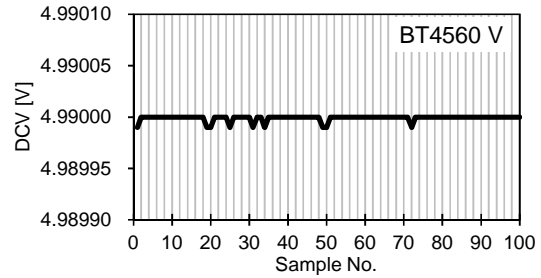

Fig. 6. V Repeatability During 4.99 V Voltage Measurement

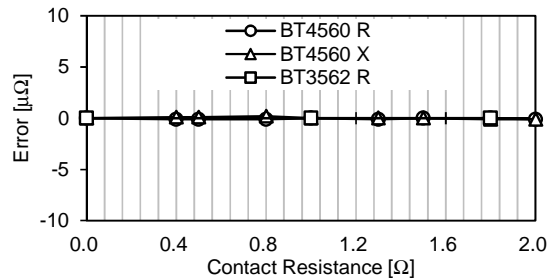

Fig. 7. Effects of Contact Resistance of SOURCE H Terminal

B. Effects of Contact Resistance

The contact resistance can vary each time the measurement probes are brought into contact with a measurement target. To obtain stable, reproducible measured values, an instrument must exhibit stability with regard to contact resistance.

Figs. 7 and 8 illustrate the amount of variation in impedance measured values relative to the contact resistance of the measurement terminals. The measurement conditions were as follows:

- Measurement target: 3 mΩ resistor element
- Measurement range: 3 mΩ
- Sampling speed: SLOW

Compared to the effects of contact resistance on the BT3562, Hioki's previous model, the BT4560 exhibits dramatically improved performance for its SENSE terminals. Performance for the SOURCE terminals is about the same as for the BT3562, with no effect up to 2.0 Ω.

Fig. 9 illustrates the effects of contact resistance during DC voltage measurement. The measurement voltage was 5 V, and there was no effect up to a contact resistance of 55 Ω.

The BT4560's strength with regard to contact resistance helps make possible stable, reproducible measurement.

The BT4560 performs a contact check between the SENSE and SOURCE terminals, and a reading of 10 Ω or greater with the 3 mΩ range is considered to indicate a measurement error. For DC voltage measurement, a reading of 50 Ω or greater is considered to indicate a measurement error.

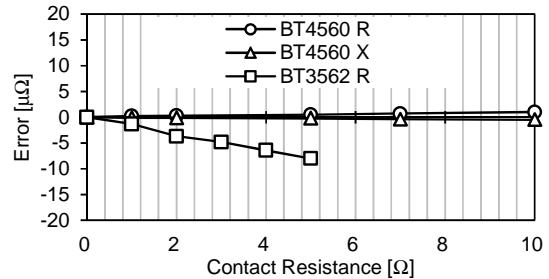

Fig. 8. Effects of Contact Resistance of SENSE H Terminal

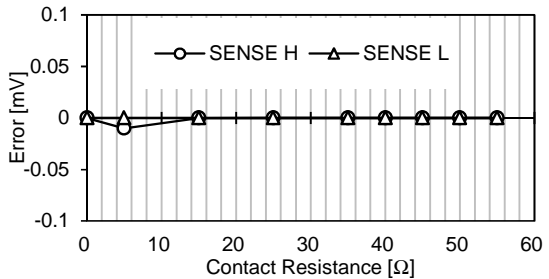

Fig. 9. Effects of Contact Resistance During Voltage Measurement

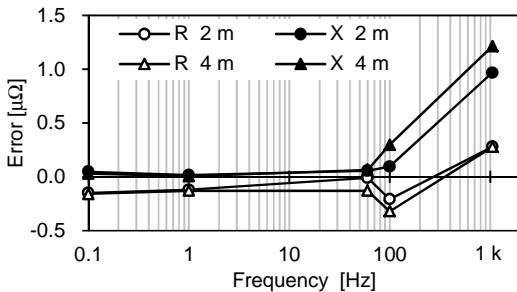

Fig. 10. Effects of Cable Length

C. Effects of Cable Length

Fig. 10 illustrates the magnitude of the effects of measurement cable length during impedance measurement. The data expresses the amount of variation relative to the measured value with a cable length of 0 m. The measurement conditions were as follows:

Measurement target: 3 mΩ resistor element
 Measurement range: 3 mΩ
 Sampling speed: SLOW

Zero-adjustment was performed for each cable length prior to measurement.

The effects of cable length were a maximum of $0.3 \mu\Omega$ (3 dgt.) for the R value and a maximum of $1.2 \mu\Omega$ (12 dgt.) for the X value, assuring accuracy for cable lengths of up to 4 m.

D. Temperature and Frequency Characteristics

Figs. 11 and 12 illustrate frequency characteristics using temperature as the parameter. Both diagrams illustrate the characteristics when measuring a 3 mΩ pure resistance. The magnitude of the effect of temperature is $1 \mu\Omega$ (10 dgt.) or less for both resistance measurement and reactance measurement. Concerning frequency characteristics, a maximum effect of about $2 \mu\Omega$ can be observed in the reactance high-frequency region, which leaves a margin of close to a factor of 10 relative to the product specifications ($Z: \pm 0.4\% \text{ rdg.}; \theta: \pm 0.3^\circ$).

E. Linear Characteristics of DC Voltage Measurement

Fig. 13 illustrates the linear characteristics of voltage measurement. The instrument delivers a more than adequate margin relative to the voltage measurement accuracy of 0.0035% rdg. ± 5 dgt. Even for -3 V measurement, where it is greatest, the error is only about $50 \mu\text{V}$ (5 dgt.).

VI. MEASUREMENT PROBES

Two types of probes are available for the BT4560, enabling the operator to choose based on the battery being measured: Clip Type Probe L2002 (see Fig. 14) and Pin Type Probe L2003 (see Fig. 15). These measurement probes use a four-terminal-pair design that incorporates a return cable for current flowing in the opposite direction as the measurement current. This design enables stable measurement that is less susceptible to the effects of environmental noise and cable routing. In addition, the probes are designed so that the distance between the current and voltage terminals remains uniform to reduce errors caused by contact.

A. Clip Type Probe L2002

This probe is designed specifically for use with laminated batteries. It incorporates a stopper to aid in positioning the probe so that the contact position remains uniform (see the right side of Fig. 14). The position of the

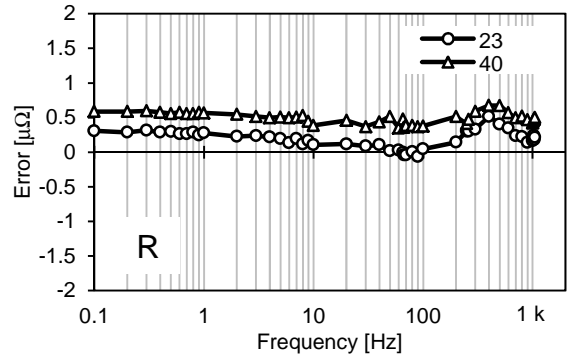

Fig. 11. Resistance Measurement Frequency Characteristics

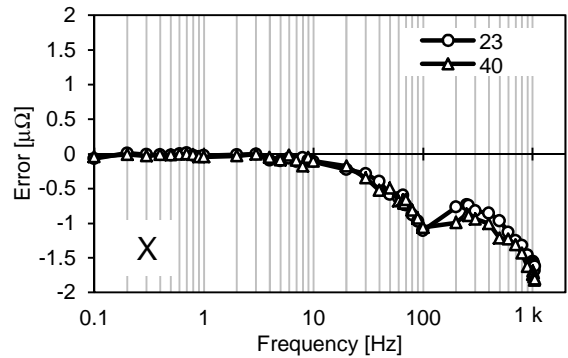

Fig. 12. Reactance Measurement Frequency Characteristics

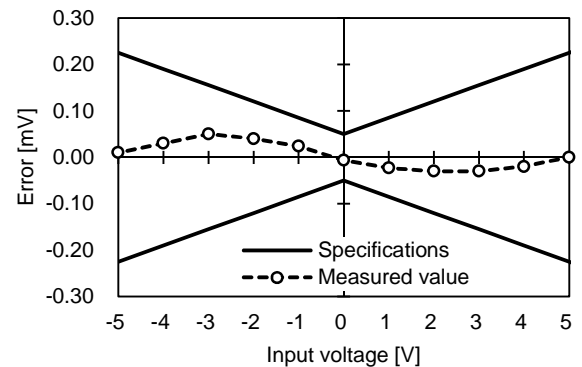

Fig. 13. DC Voltage Measurement Accuracy Linear Characteristics

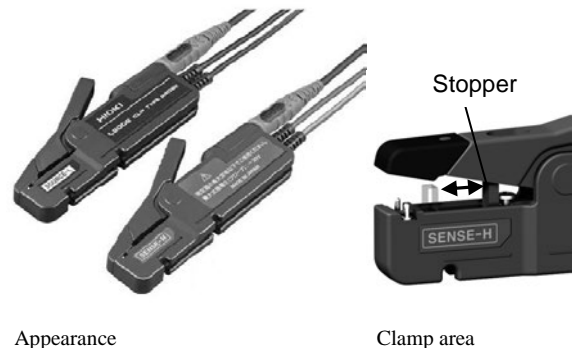

Fig. 14. L2002

Battery Impedance Meter BT4560

stopper can be adjusted based on the length of the electrode. In addition, the tip pins can be replaced in case of failure and to accommodate user preferences concerning pin profile.

B. Pin Type Probe L2003

This probe can be used to measure a variety of different battery types. Mounting holes enable the probe to be fixed in place, for example on a testing apparatus (see the right side of Fig. 15). As with the L2002, the tip pins can be replaced in case of failure and to accommodate user preferences concerning pin profile.

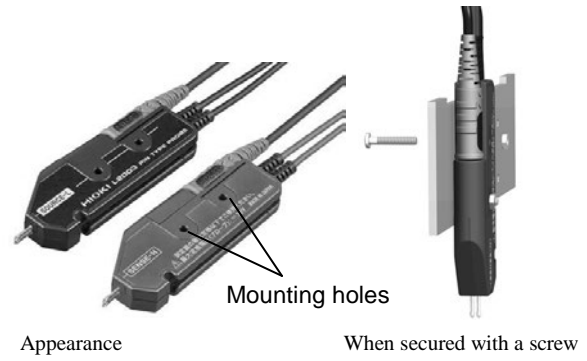

Fig. 15. L2003

VII. EXAMPLE USES

A. DC-IR Alternative Measurement

Hioki investigated the correlation in internal resistance measured values between DC-IR measurement (the conventional method) and low-frequency AC-IR measurement. Fig. 16 illustrates the results of that investigation. Drawing an approximation of the line along which the results lie yields an R^2 value of 0.99 (R : coefficient of correlation), indicating a strong correlation between low-frequency AC-IR and DC-IR resistance values. Measured values are also close. These results indicate that low-frequency AC-IR measurement is effective as an alternative to DC-IR measurement.

B. Diagnosis of Degradation

Hioki measured an actual lithium-ion battery and investigated the relationship between its degradation and the resulting Cole-Cole plots, as illustrated in Fig. 17. An internal resistance of 1 kHz is generally used to detect degradation of lead-acid batteries, but the change in low-frequency internal resistance in lithium-ion batteries is even more striking. Whereas the change in resistance at 1 kHz is about 1 m Ω , the change in resistance at 1 Hz is about 3 m Ω . This difference is due to the fact that low-frequency measurement provides a glimpse of degradation in the chemical reactions at the electrode interface as well as of degradation of the battery's electrolyte. Diagnosis of degradation using low-frequency measurement is an area in which Hioki expects to see innovation in the future.

VIII. CONCLUSION

The BT4560, which embodies a proposal of low-frequency AC-IR measurement, was designed to resolve issues in the production processes. Hioki expects that it will find use in a broad range of lithium-ion battery evaluation and test settings and that it will contribute to social progress.

Hideaki Tanaka^{*1}, Hideyuki Nagai^{*1}, Junji Iijima^{*1},
Chihiro Narusawa^{*2}, Muhamed Musadiq^{*3}

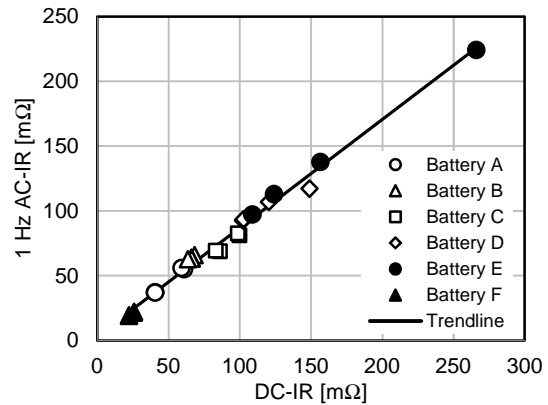

Fig. 16. Correlation Between Low-frequency AC-IR and DC-IR

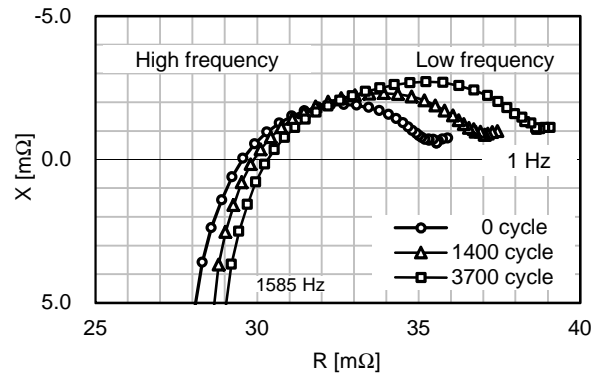

Fig. 17. Relationship Between Battery Degradation and Cole-Cole Plots (Lithium-ion battery)

*1 Engineering Division 2, Engineering Department

*2 Engineering Division 3, Engineering Department

*3 Engineering Division 10, Engineering Department