

HIOKI

9593-03

Instruction Manual

RS-232C INTERFACE

For 3157 AC GROUNDING HiTESTER

EN

Mar. 2022 Revised edition 1
9593C981-01 22-03H



Contents

Introduction	i
Chapter 1 Before Use	1
1.1 Check of External Appearance and Accessories	1
1.2 Shipping Precautions	2
1.3 Notes on Use	3
1.4 Installing the RS-232C Interface	4
Chapter 2 Overview	5
2.1 Introduction to the RS-232C Interface	5
2.2 Features	6
2.3 Specifications	7
Chapter 3 Names of Parts	7
3.1 Controls and Connections	7
Chapter 4 Operation	9
4.1 Setting the RS-232C Communication Conditions	9
4.2 Communication Methods by the RS-232C	10
4.3 Message Format	11
4.3.1 Program Message	11
4.3.2 Response Messages	11
4.4 Headers	12
4.5 Data Formats	13
4.6 Delimiters	14
4.7 Separators	14
4.8 Abbreviation of Compound Commands	15
4.9 Output Queue	16
4.10 Input Buffer	16
4.11 Event Registers	17



Chapter 5 Command Reference	19
5.1 Command Summary	19
5.2 Format of Command Explanations	22
5.3 Particular Commands	23
5.4 Commands Specific to the 3157	25
5.5 Response Format for Queries as Numerical Value	57
5.6 Initialization Items	58
Chapter 6 Troubleshooting	59

Introduction

Thank you for purchasing this HIOKI "9593-03 RS-232C INTERFACE."
To get the maximum performance from the unit, please read this manual first,
and keep this at hand.

This Instruction Manual provides information and warnings essential for
operating this equipment in a safe manner and for maintaining it in safe
operating condition. Before using this equipment, be sure to carefully read the
following safety notes.

The following symbols are used in this Instruction Manual to indicate the
relative importance of cautions and warnings.

	Indicates that incorrect operation presents significant danger of accident resulting in death or serious injury to the user.
	Indicates that incorrect operation presents possibility of injury to the user or damage to the equipment.
	Denotes items of advice related to performance of the equipment or to its correct operation.

* The "3157" in this Instruction Manual includes the "3157-01."

Chapter 1

Before Use

1.1 Check of External Appearance and Accessories

When the unit is delivered, check and make sure that it has not been damaged in transit. If the unit is damaged, or fails to operate according to the specifications, contact your dealer or HIOKI representative.

- (1) 9593-03 RS-232C INTERFACE
- (2) This instruction manual

1.2 Shipping Precautions

If reshipping the unit, preferably use the original packing.

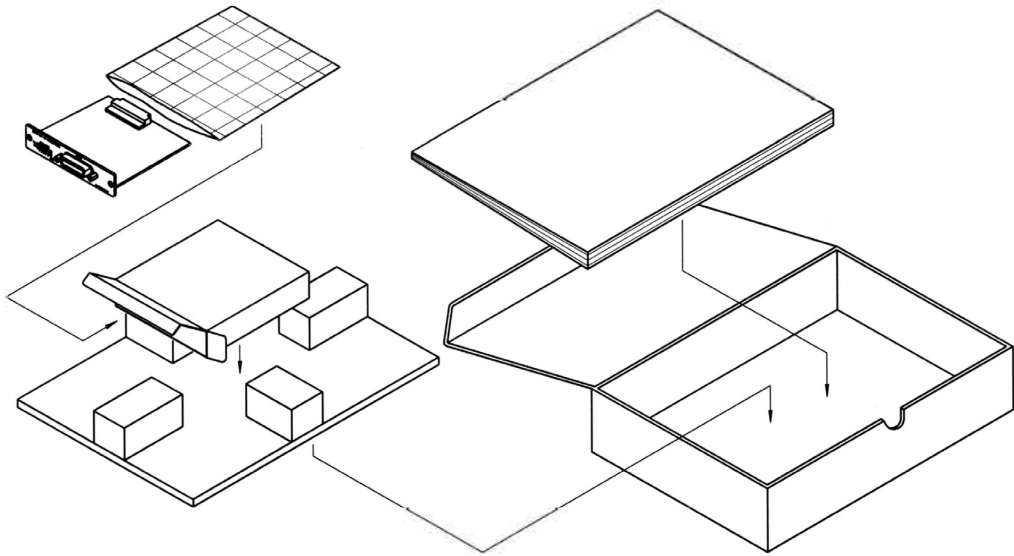

If this is not available, use the following procedure.

- (1) Wrap the unit in plastic sheeting.
- (2) After wrapping cushioning material around the unit, pack it into a cardboard box, and then seal up the box with adhesive tape.

1.3 Notes on Use

- (1) If you change the communication conditions of the 3157 while using it, you should immediately turn the power off and on again. If you do not do so, the communication conditions will not be changed to the new ones.
- (2) Always be sure to secure the RS-232C cable to the 9593-03 unit by tightening up the fixing screws provided.
- (3) Program messages sent just after the power has been turned on are executed after the self test has terminated.
- (4) It is vital that the proper data format is used when inputting commands with data values to the 3157 unit.
- (5) For details of the various functions, refer to the instruction manual for the 3157 unit.

1.4 Installing the RS-232C Interface

○ WARNING

- To prevent electrical shock, before adding or replacing the RS-232C interface, check that the power for the unit is off and the power cord and connectors are disconnected. [The fixing screws must be firmly tightened or the input unit may not function up to specification, or may even fail.]
- To avoid the danger of electric shock, never operate the unit with an RS-232C interface removed. If you should wish to use the unit after removing an interface, fit a blank panel over the opening of the removed unit.

○ CAUTION

When inserting in the interface, hold the metal plate. Directly touching the board may cause static electricity and lead to damage of the instrument. (Using the wrist strap for preventing static electricity when inserting is recommended.)

The space for fitting the 9593-03 RS-232C INTERFACE in the rear panel of the 3157 is covered with a blank panel. Follow these three steps to install the 9593-03 interface.

Set the communication conditions prior to installation. For the setting procedure, see Section 4.1, "Setting the RS-232C Communication Conditions."

- (1) Remove the fixing screws, and take off the blank panel.
- (2) Insert the 9593-03 RS-232C INTERFACE into the exposed slot in the rear of the unit in the figure below.
- (3) Push the 9593-03 firmly into place, and fix with the screws removed in step 1.

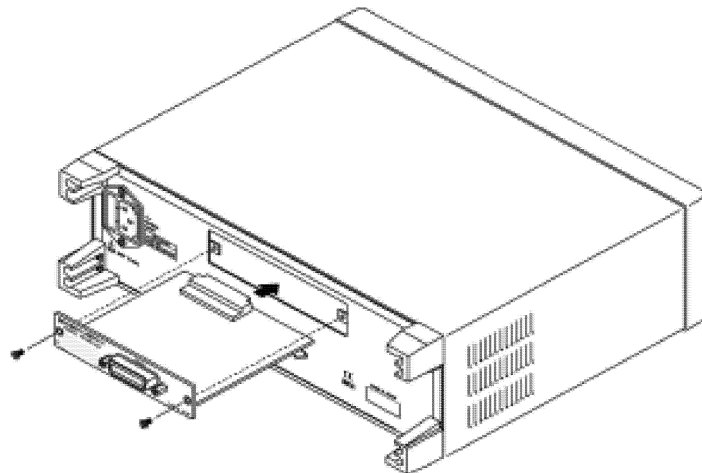

Chapter 2

Overview

2.1 Introduction to the RS-232C Interface

By connecting the 9593-03 RS-232C INTERFACE to the 3157 AC GROUNDING HiTESTER, it is possible to control all the functions of the main unit (except for powering on and off) via the RS-232C bus.

2.2 Features

- (1) All of the functions of the 3157 main unit, except for powering on and off, can be controlled via the RS-232C interface. However, the ":START" command works in a state in which the momentary OUT settings are disabled even though the momentary OUT settings have been set.
- (2) The beeper sound can be turned on and off.
- (3) The unit can be reset.

2.3 Specifications

General specifications

Operating environment	Indoor use, pollution degree 2, altitude up to 2000 m (6562 ft.)
Operating temperature and humidity range	0°C to 40°C (32°F to 104°F) 90% RH (non-condensing)
Storage temperature and humidity range	-10°C to 50°C (14°F to 122°F) 95% RH (non-condensing)
Standards	EMC EN 61326 Class A Safety EN 61010
Interface	RS-232C
Dimensions	Approx. 123.5 mmW × 27 mmH × 94.9 mmD (4.86"W × 1.06"H × 3.74"D)
Weight	Approx. 82 g (2.9 oz.)
Product warranty duration	3 years
Accessory	Instruction manual

Interface specifications

Transfer system	Start-stop synchronization, full duplex
Baud rate	2400 bps, 4800 bps, 9600 bps, 19200 bps
Data length	7 bit, 8 bit
Parity	Even, odd, or none
Stop bit	1 bit, 2 bit
Delimiter	When sending: CR+LF, CR When receiving: CR+LF, CR (no setting)
Handshake	Not provided

Set using the DIP switches.

Connector

D-sub 9-pin male with #4-40 locking screws
The connector on the 9593-03 is for terminal (DTE).

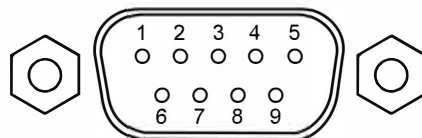

Signal assignments and explanation

PIN No.	Signal name		Input/output	Signal
	Common	JIS		
1	DCD	CD	(Unconnected)	Carrier detection
2	RxD	RD	IN	Receive data
3	TxD	SD	OUT	Transmit data
4	DTR	ER	(Fixed at ON level)	Data terminal ready
5	GND	SG	GND	Ground
6	DSR	DR	(Unconnected)	Data set ready
7	RTS	RS	(Fixed at ON level)	Request for send
8	CTS	CS	(Unconnected)	Clear to send
9	RI	CI	(Unconnected)	Calling indicator

Chapter 3

Names of Parts

3.1 Controls and Connections

(1) 3157 front panel

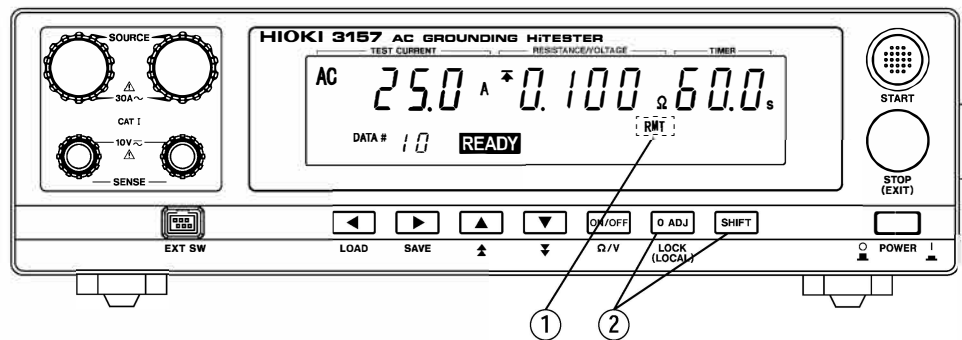

① Display of RS-232C status

Each lamp displays the state of control by the RS-232C.

RMT: Remote

② Remote state releasing keys

Press the **O ADJ** key while holding down the **SHIFT** key to release the remote state by the RS-232C and resume the local state. However, this key operation is disabled if the RS-232C controller has put the unit into the local lock out state. (Pressing **SHIFT** + **O ADJ** has no effect.)

When the unit enters the remote state because of a command message, it is forcibly returned to the READY state.

(2) 9593-03 RS-232C interface

Top view

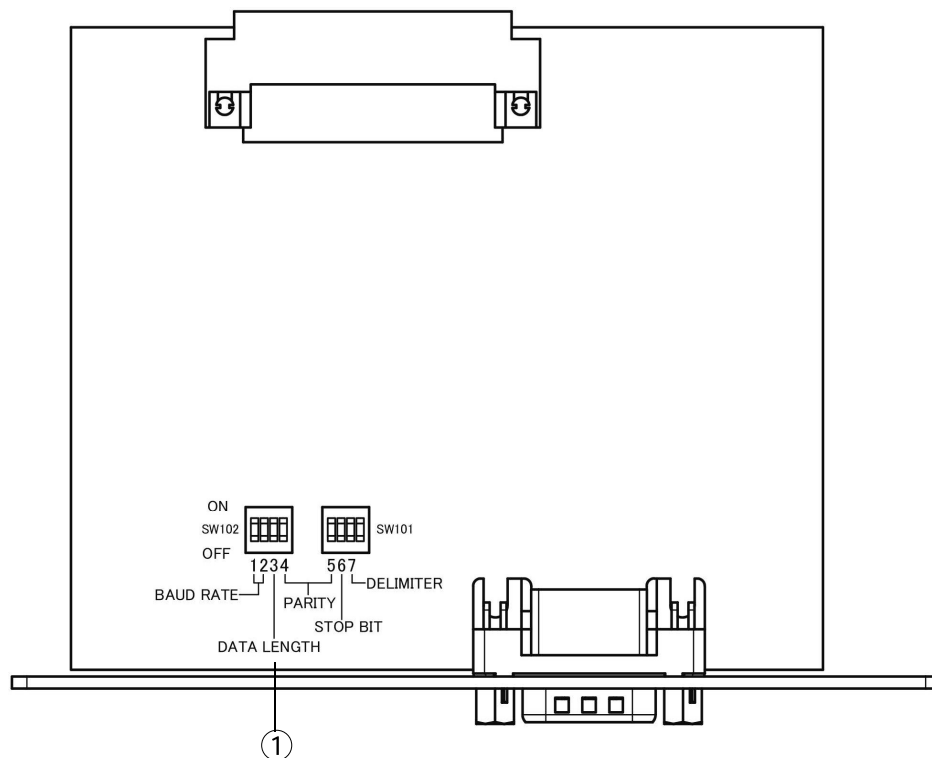

Front view

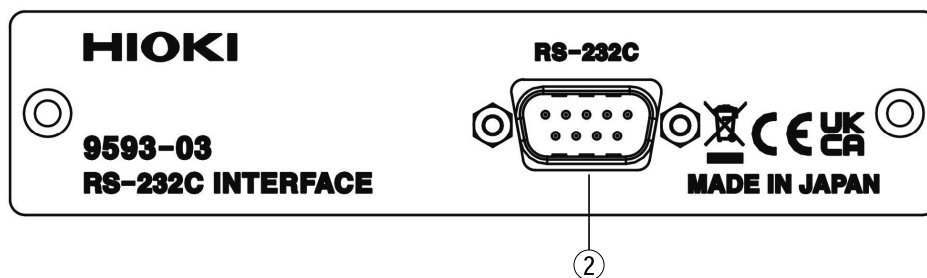

① Communication condition setting switches

These are used to set the communication conditions of the 3157 unit on the RS-232C bus. For how to set these switches, refer to Section 4.1, "Setting the RS-232C Communication Conditions."

② RS-232C connector

Connect the RS-232C cable to this connector.

Chapter 4

Operation

4.1 Setting the RS-232C Communication Conditions

- Use the communication condition setting switches on the RS-232C panel to set the communication conditions.
- On dispatch from the factory, this address is initially set to 00000001.

Bit	1	2	3	4	5	6	7	8
Description	Baud rate		Data length	Parity		Stop bit	Delimiter	(Fixed)

BAUD RATE

Bits 1 2	Baud rate
0 0	9600
0 1	4800
1 0	2400
1 1	19200

DATA LENGTH

Bit 3	Data length
0	8 bits
1	7 bits

PARITY

Bits 4 5	Parity
0 0	None
0 1	None
1 0	Even
1 1	Odd

Bits 6	Stop bit
0	1 bit
1	2 bit

DELIMITER (when sending)

Bit 7	Delimiter
0	CR+LF
1	CR

0: OFF, 1: ON

NOTE

- If you change the communication conditions while the 3157 is being used, then you should immediately turn the power off and on again. If this is not done, the communication conditions will not be changed to the new ones.
- When the 3157 soft start mode is enabled, its operation slows down at starting test. This may cause a communication error, depending on the preset baud rate.
- Bit 8 is fixed at "1" (on). Switching it will cause improper operation.

4.2 Communication Methods by the RS-232C

In order to control the 3157 by the RS-232C, there are several kinds of messages.

Of these, program messages are those received by the 3157 from the computer, while response messages are those sent from the 3157 to the computer.

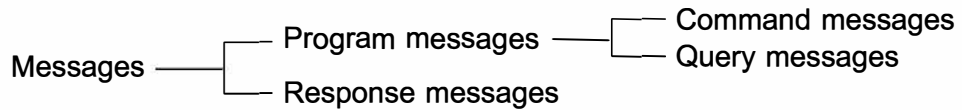

(1) Program messages

Program messages are command messages or query messages.

- **Command messages** are orders for controls of the 3157, such as for making unit settings or for reset or the like.

Example :TIMER_<data>

(Command message which enables and disables the test time)

- **Query messages** are orders for responses relating to results of operation, results of measurement, or the state of 3157 settings. A question mark "?" is suffixed at the end of the command.

Example :TIMER?

(Queries the current test time enablement)

(2) Response messages

It represents the response data for query messages from the 3157.

Example :TIMER_ON

(Test time is currently enabled.)

NOTE

A space is represented by "_" in the examples.

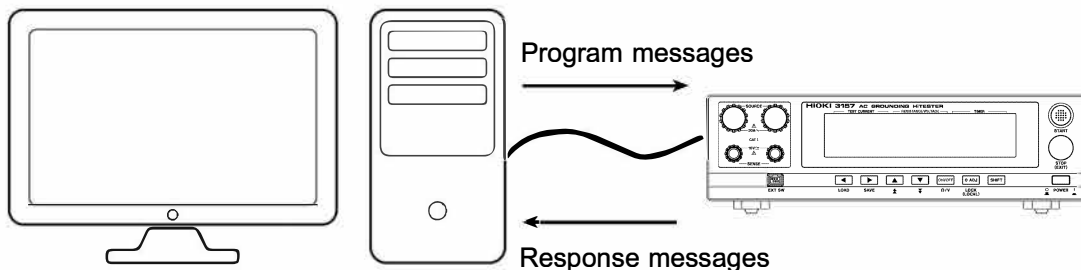

4.3 Message Format

The commands for the 3157 are as far as possible mnemonic. Furthermore, all commands have a long form, and an abbreviated short form.

4.3.1 Program Message

The program message is made up from header and data portions.

Example Command message to set test time to ON

```
:TIMER_ON
  ↑      ↑
  ①      ②
```

①: Header portion

②: Data portion (ASCII-format text or numeric values. Some messages have no data portions...query messages, etc.)

A command header can be abbreviated. The whole command form is referred to as the "long form" and the abbreviated form as the "short form."

In this manual, the short form is written in upper case letters, and then this is continued in lower case letters so as to constitute the long form. Either of these forms will be accepted during operation, but intermediate forms will not be accepted. Further, during operation both lower case letters and upper case letters will be accepted without distinction.

For "TIMER", either "TImEr" (the long form) or "TIM" (the short form) will be accepted. However, any one of "TIME", or "TI" is wrong and will generate an error.

4.3.2 Response Messages

It represents the response message for query messages from the 3157.

Response messages generated by the 3157 are in long form and in upper case letters.

Example :TIMER_ON
(Test time is currently enabled.)

NOTE

If an error occurs when the query message is received, the query does not produce response message.

4.4 Headers

(1) Program message headers

There are three types of header: simple headers, compound headers, and particular headers.

(2) Simple header

A header consisting of a single word beginning with a letter.

Examples :HEADer etc.

(3) Compound header

A header consisting of a sequence of words separated by colons.

Examples :CONFigure:CURRent, MEASure:RESistance?, etc.

(4) Particular header

A header beginning with an asterisk (*) to indicate that it is a particular command.

Examples *RST etc.

(2) Response message

Headers in response messages can be enabled or disabled by using the "HEADer" command.

Example When test time is enabled:

:TIMER?

(Query message asking for the current enablement state of the test time)

Response message when headers are on.

:TIMER_ON

↑
①

↑
②

①: Header portion

②: Data portion

Response message when headers are off.

ON

Data portion only

4.5 Data Formats

The 3157 uses character string data and decimal numeric data, and the type used varies according to the command in question.

(1) Character data

Character string data must always begin with an alphabetic character, and the characters following can be either alphabetic characters or numerals. Although in character data either upper case letters or lower case letters are accepted, response messages output by the 3157 are always in upper case letters.

Example :STATE_reaDY

(2) Decimal data

The numeric data values are all represented in decimal, in three formats identified as NR1, NR2 and NR3, and each of these can appear as either a signed number or an unsigned number. Unsigned numbers are taken as positive. Further, if the accuracy of a numerical value exceeds the limit which the 3157 can deal, it is rounded off (5 and above is rounded up; 4 and below is rounded down).

NR1 format: Integer data

Examples +3000, -50000, 210

NR2 format: Fixed point numbers

Examples +2.56, -30.45, 300.28

NR3 format: Floating point numbers.

Examples +3E-2, -1.2E3

The term "NRf format" includes all these three formats. When the 3157 is receiving it accepts NRf format, but when it is sending response messages it utilizes whichever one of the formats NR1 to NR3 is indicated in the specified command.

Examples :CONFigure:CURRent_25

:CONFigure:CURRent_+25.012

:CONFigure:CURRent_0.0025E4

4.6 Delimiters

The term "delimiter" is used to refer to the following possibility for separating data sequences.

The 3157 recognizes a carriage return plus linefeed (CR+LF) or a carriage return (CR) as delimiters.

NOTE

The 3157 only begins to analyze a command after recognizing the delimiter.

4.7 Separators

(1) Message unit separator

A semicolon (;) is used as a message unit separator when it is desired to set out several messages on a single line.

Example :UNIT_OHM;;UPPER_ON;;CONFIGURE:RUPPER_0.100

NOTE

When messages are combined in this way, if a syntax error occurs, all subsequent messages up to the next delimiter will be ignored.

(2) Header separator

In a message which has a header and data, a space (represented by "_" in the examples) is used as the header separator to separate the header from the data.

Example :ADjust_ON

(3) Data separator

If a message has several data items, commas (,) are required as data separators for separating these data items from one another.

Example :KEY_< first byte>, <second byte>

4.8 Abbreviation of Compound Commands

When several compound commands have a common head portion (for example, :CONFigure:CURRent and :CONFigure:RUPPer, etc.), then, when and only when writing them directly following on from one another, this common portion (:CONFigure in this example) can be omitted from each command except for the first one.

This common portion is called "the current path", by analogy with the general concept of the current directory in the directory structure of UNIX or MSDOS, and until it is cleared the analysis of following commands is performed by deeming them to be preceded by the current path which has been curtailed in the interests of brevity. This manner of using the current path is shown in the following example:

Normal expression

:CONFigure:CURRent_25.0;:CONFigure:RUPPer_0.100

Abbreviated expression

:CONFigure:CURRent_25.0;RUPPer_0.100

↑ This becomes the current path, and can be curtailed from the following commands.

The current path is cleared when the power is turned on, when a colon (:) appears at the start of a command, and when a delimiter is detected.

Messages with particular headers can be executed without relation to the current path. Further, they have no effect upon the current path.

With the 3157, there are 4 possible current paths:

:CONFigure:

:MEASure:

:MEMory:

:SYSTEM:

4.9 Output Queue

Response messages accumulate in the output queue and are transmitted as data and cleared.

The output queue is also cleared when the power is turned off and turned on again.

The 3157 has an output queue of 300 bytes capacity. If the response messages overflow this limit of 300 bytes, a query error is generated, and the output queue is cleared.

4.10 Input Buffer

The 3157 has an input buffer of 300 bytes capacity. When more than 300 bytes of data are transmitted, when the buffer is full any subsequent bytes received will be ignored.

4.11 Event Registers

The 3157 includes two 8-bit event registers. It is possible to determine the status of the unit by reading these registers.

The event register is cleared in the following situations:

- When a "*CLS" command is executed.
- When an event register query is executed. (*ESR?, :ESR0?)
- When the unit is powered on.

(1) Standard event status register (SESR) bit assignments

Bit 7 PON	Power on flag. When the power is turned on, or on recovery from a power cut, this bit is set to 1.
Bit 6	Unused.
Bit 5 CME	Command error. When a command which has been received contains a syntactic or semantic error, this bit is set to 1. <ul style="list-style-type: none"> • The command is not supported by the 3157. • There is a mistake in a program header. • The number of data parameters is wrong. • The format of the parameters is wrong.
Bit 4 EXE	Execution error. When for some reason a command which has been received cannot be executed, this bit is set to 1. <ul style="list-style-type: none"> • The designated data value is outside the set range. • The designated data value is not acceptable.
Bit 3 DDE	Device dependent error. When a command cannot be executed due to some cause other than a command error, a query error, or an execution error, this bit is set to 1. <ul style="list-style-type: none"> • Execution is impossible due to an abnormality inside the 3157.
Bit 2 QYE	Query error. This bit is set to 1 when a query error is detected by the output queue control. <ul style="list-style-type: none"> • When the data overflows the output queue. • When data in the output queue has been lost.
Bit 1	Unused.
Bit 0	Unused.

(2) Event status register 0 (ESR0) bit assignments

Bit 7	Unused
Bit 6	Unused
Bit 5	Unused
Bit 4	Unused
Bit 3 EOM	Test completed
Bit 2 LFAIL	Below lower limit of comparator
Bit 1 UFAIL	Above upper limit of comparator
Bit 0 PASS	Within limits of comparator

Chapter 5

Command Reference

5.1 Command Summary

Particular commands

Command	Explanation	Ref page
*CLS	Clears event register.	23
*ESR?	Queries standard event status register (SESR).	23
*IDN?	Queries device ID.	23
*RST	Device initialization.	24
*TST?	Queries the result of the self-test.	24

Commands specific to the 3157

Command	Explanation	Ref page
:ADJust	Enables and disables the zero adjustment function.	25
:ADJust?	Queries the zero adjustment function enablement.	25
:CONFigure?	Queries the test settings.	26
:CONFigure:CURRent	Sets the output current value.	26
:CONFigure:CURRent?	Queries the output current value.	27
:CONFigure:DATA	Sets the number of test data.	27
:CONFigure:DATA?	Queries the number of test data.	27
:CONFigure:RLOWer	Sets the minimum test value (resistance).	28
:CONFigure:RLOWer?	Queries the minimum test value (resistance).	28
:CONFigure:RUPPer	Sets the maximum test value (resistance).	29
:CONFigure:RUPPer?	Queries the maximum test value (resistance).	29
:CONFigure:TIMer	Sets the test time.	30
:CONFigure:TIMer?	Queries the test time.	30
:CONFigure:VLOWer	Sets the minimum test value (voltage).	31
:CONFigure:VLOWer?	Queries the minimum test value (voltage).	31
:CONFigure:VUPPer	Sets the maximum test value (voltage).	32
:CONFigure:VUPPer?	Queries the maximum test value (voltage).	32
:ESR0?	Queries event status register 0.	32
:HEADer	Enables and disables headers for the response messages.	33
:HEADer?	Queries whether or not headers on response messages are enabled.	33
:KEY	Sets key entry.	34
:LOWer	Enables and disables the minimum test value.	34
:LOWer?	Queries the minimum test value enablement.	35
:MEASure:CURRent?	Queries the measured current value.	35
:MEASure:RESistance?	Queries the measured resistance value.	36
:MEASure:TIMer?	Queries the test time elapsed.	36
:MEASure:VOLTage?	Queries the measured voltage value.	37
:MEASure:RESult:VOLTage?	Queries the measured value and result (voltage).	37
:MEASure:RESult:RESistance?	Queries the measured value and result (resistance).	38
:MEMory:CLEar	Clears Setting memory.	38
:MEMory:FILE?	Queries the contents of Setting memory.	39
:MEMory:LOAD	Loads Setting memory.	39
:MEMory:SAVE	Saves in Setting memory.	40
:STARt	Starts a test.	40
:STATe?	Queries the state.	40
:STOP	Performs forcible ending of a test and releases the hold state.	41
:SYSTem:ERRor?	Queries RS-232C communication condition errors.	41

Command	Explanation	Ref page
:SYSTem:OPTion:BUZZer	Sets the buzzer.	42
:SYSTem:OPTion:BUZZer?	Queries the buzzer.	42
:SYSTem:OPTion:CCHange	Sets the current changeability in the TEST state.	43
:SYSTem:OPTion:CCHange?	Queries the current changeability in the TEST state.	43
:SYSTem:OPTion:CDATa	Sets the maximum number of test data in the test data count function.	44
:SYSTem:OPTion:CDATa?	Queries the maximum number of test data in the test data count function.	44
:SYSTem:OPTion:COUNT	Sets the test data count function.	45
:SYSTem:OPTion:COUNT?	Queries the test data count function.	45
:SYSTem:OPTion:ENDLess	Sets the endless timer function.	46
:SYSTem:OPTion:ENDLess?	Queries the endless timer function.	46
:SYSTem:OPTion:FREQUency	Sets the output current frequency.	47
:SYSTem:OPTion:FREQUency?	Queries the output current frequency.	47
:SYSTem:OPTion:HOLD	Sets the hold function.	48
:SYSTem:OPTion:HOLD?	Queries the hold function.	48
:SYSTem:OPTion:LOWer	Sets the minimum test value.	49
:SYSTem:OPTion:LOWer?	Queries the minimum test value.	49
:SYSTem:OPTion:MOMentary	Sets the momentary OUT function.	50
:SYSTem:OPTion:MOMentary?	Queries the momentary OUT function.	50
:SYSTem:OPTion:PFHold	Sets the PASS/FAIL hold function.	51
:SYSTem:OPTion:PFHold?	Queries the PASS/FAIL hold function.	51
:SYSTem:OPTion:PRINter	Sets the printer output function.	52
:SYSTem:OPTion:PRINter?	Queries the printer output function.	52
:SYSTem:OPTion:TMODE	Sets the test mode.	53
:SYSTem:OPTion:TMODE?	Queries the test mode.	53
:TIMer	Enables and disables the test time.	54
:TIMer?	Queries the test time enablement.	54
:UNIT	Sets the unit of the maximum and minimum test values.	55
:UNIT?	Queries the unit of the maximum and minimum test values.	55
:UPPer	Enables and disables the maximum test value.	56
:UPPer?	Queries the maximum test value enablement.	56

5.2 Format of Command Explanations

Syntax	Specifies the syntax for the command (a space is represented by "_" in this syntax).
<data>	For a command that has parameters, specifies their format.
Function	Specifies the function of the command.
Note	Specifies precautions to be taken when using the command.
Example	These are simple examples of the use of the command. Note that all transmission messages are expressed in a "short form."
Error	Specifies what types of error may occur. Any spelling error in a message results in a command error.

NOTE

For details of each function, refer to the instruction manual for the 3157 unit.

5.3 Particular Commands

*CLS

- Clears the status byte register and the event registers.

Syntax *CLS

- Function**
- Clears all the event registers (SESR, ESR0) associated with the bits of the status byte register. Accordingly, also clears the status byte register.
 - This has no effect upon the output queue.

Error If the data parameters are set after this command, a command error occurs.

*ESR?

- Queries the contents of the standard event status register (SESR).

Syntax *ESR?

- Function**
- Returns the contents of the standard event status register (SESR) as a numerical value in NR1 format between 0 and 255, and then clears standard event status register.
 - No header is affixed to the response message.

Example Response 32
Bit 5 of SESR has been set to 1.

128	64	32	16	8	4	2	1
bit 7	bit 6	bit 5	bit 4	bit 3	bit 2	bit 1	bit 0
PON	URQ	CME	EXE	DDE	QYE	RQC	OPC

Standard event status register (SESR)

Error If the response message is longer than 300 bytes, a query error is generated.

*IDN?

- Queries manufacturer's name, model name, and software version.

Syntax *IDN?

- Function**
- The response consists of the name of the manufacturer of the unit, the model name, and the software version.
 - No header is affixed to the response message.
- First field Manufacturer's name
Second field Model name
Third field Serial number (Not used - always zero)
Fourth field Software version

Example Response HIOKI,3157,0,V01.01

Error If the response message is longer than 300 bytes, a query error is generated.

***RST**

■ Performs device initial setting.

Syntax *RST

Function Resets the 3157. The items which are reset are listed below.

Voltage or resistance indicator (unit)	Resistance
Test time enablement	ON
Maximum test value enablement	ON
Minimum test value enablement	OFF
Output current value	25.0 A
Maximum test value (resistance)	0.100 Ω
Minimum test value (resistance)	0.000 Ω
Maximum test value (voltage)	2.50 V
Minimum test value (voltage)	0.00 V
Test time	60.0 s

Error If the data parameters are set after this command, a command error occurs.

***TST?**

■ Requests execution of, and queries the result of, the self test.

Syntax *TST?

Function

- Performs the self test of the 3157, and returns the result thereof as a numerical value in NR1 format between 0 and 3.
- No header is affixed to the response message.
 - Bit 0: A ROM error occurred.
 - Bit 1: A RAM error occurred.
 - Bits 2 to 7: Unused

Example Response 3
A ROM error (bit 0) and a RAM error (bit 1) have occurred.

Error If the response message is longer than 300 bytes, a query error occurs. The execution of this command in a state other than the READY state causes an execution error.

5.4 Commands Specific to the 3157

:ADJust

- Enables and disables the zero adjustment function.

Syntax :ADJust_<data>

<data> ON/OFF (character data)

Function Turns the zero adjustment function on and off.

Example Transmission :ADJust ON
The zero adjustment function is turned on.

Error If <data> is other than character data and numerical value described above, a command error occurs.
The execution of this command in a state other than the READY state causes an execution error.

:ADJust?

- Queries the zero adjustment function enablement.

Syntax :ADJust?

Function Returns the current enablement state of the zero adjustment function as character data.

<data> ON/OFF (character data)

Example Response
If headers are on :ADJUST ON
If headers are off ON

Error If the response message is longer than 300 bytes, a query error is generated.

:CONFigure?

- Queries the test settings.

Syntax	:CONFigure?
Function	Returns as data the test settings as <output current value>, <maximum test value>, <minimum test value>, <test time> in order. If the unit of the maximum and minimum test values is set to "OHM" (resistance), the maximum and minimum test values are expressed as resistance values. If the unit of the maximum and minimum test values is set to "VOLT" (voltage), the maximum and minimum test values are expressed as voltage values.
<data>	Output current value: Numerical value in NR2 format Maximum test value, minimum test value, test time: OFF, --- (character data), or numerical value in NR2 format When the minimum test value is not set, returns "---." When the minimum test value is set and set to OFF, returns "OFF." When the endless timer function is set, returns "---." When the endless timer function is not set, and the test time is set to OFF, returns "OFF."
Example	Response If headers are on :CONFIGURE 25.0,0.100,0.000,60.0 If headers are off 25.0,0.100,0.000,60.0
Error	If the response message is longer than 300 bytes, a query error is generated.

:CONFigure:CURRent

- Sets the output current value.

Syntax	:CONFigure:CURRent_<data>
<data>	Numerical data in NR2 format between 3.0 and 31.0
Function	Sets the output current value. The numerical value can be in NRf format, but rounding is performed for figures beyond the last valid decimal place.
Example	Transmission :CONFigure:CURRent 25.0 The output current value is set to 25.0 A.
Error	If <data> is other than numerical value described above, an execution error occurs. The execution of this command in a state other than the READY state causes an execution error. However, when the current value can be changed in the TEST state, this command is executed even in the TEST state.

:CONFigure:CURRent?

- Queries the output current value.

Syntax :CONFigure:CURRent?

Function Returns the output current value setting as a numerical value in NR2 format.

<data> Numerical data in NR2 format between 3.0 and 31.0

Note If the output current value is reset in the TEST state (test in progress), the reset value is returned. On completion of the test, however, the value that was set before the test is returned.

Example Response
 If headers are on :CONFIGURE:CURRENT 25.0
 If headers are off 25.0

Error If the response message is longer than 300 bytes, a query error is generated.

:CONFigure:DATA

- Sets the number of test data.

Syntax :CONFigure:DATA_<data>

<data> Numerical data in NR1 format between 1 and 99

Function Sets the number of test data.
 The numerical value can be in NRf format, but any digits after the decimal point will be rounded.

Example Transmission :CONFigure:DATA 10
 The number of test data is set to 10.

Error If <data> is other than numerical value described above, an execution error occurs.
 The execution of this command in a state other than the READY state causes an execution error.
 If a number exceeding the maximum number of test data in the test data count function is set, an execution error occurs.

:CONFigure:DATA?

- Queries the number of test data.

Syntax :CONFigure:DATA?

Function Returns the setting for the number of test data as a numerical value in NR1 format.

<data> Numerical data in NR1 format between 1 and 99

Example Response
 If headers are on :CONFIGURE:DATA 10
 If headers are off 10

Error If the response message is longer than 300 bytes, a query error is generated.

:CONFigure:RLOWer

- Sets the minimum test value (resistance).

Syntax :CONFigure:RLOWer_<data>

<data> Numerical data in NR2 format between 0.000 and 2.000

Function Sets the minimum test value (resistance).
The numerical value can be in NRf format, but rounding is performed for figures beyond the last valid decimal place.

Note The minimum test value (resistance) can be used as the basis for the test only when the maximum and minimum test values are set to be expressed in "OHM" (resistance) and when the minimum test value setting is not disabled, and when "ON" is selected in the ON/OFF setting for the minimum test value.

Example Transmission :CONFigure:RLOWer 0.000
The minimum test value (resistance) is set to 0.000 Ω .

Error If <data> is other than numerical value described above, an execution error occurs.
The execution of this command in a state other than the READY state causes an execution error.

:CONFigure:RLOWer?

- Queries the minimum test value (resistance).

Syntax :CONFigure:RLOWer?

Function Returns the minimum test value (resistance) setting as a numerical value in NR2 format.

<data> Numerical data in NR2 format between 0.000 and 2.000

Example Response
If headers are on :CONFigure:RLOWer 0.000
If headers are off 0.000

Error If the response message is longer than 300 bytes, a query error is generated.

:CONFigure:RUPPer

■ Sets the maximum test value (resistance).

Syntax :CONFigure:RUPPer_<data>

<data> Numerical data in NR2 format between 0.000 and 2.000

Function Sets the maximum test value (resistance).
The numerical value can be in NRf format, but rounding is performed for figures beyond the last valid decimal place.

Note The maximum test value (resistance) can be used as the basis for the test only when the maximum and minimum test values are set to be expressed in "OHM" (resistance) and when "ON" is selected in the ON/OFF setting for the maximum test value.

Example Transmission :CONFigure:RUPPer 0.100
The maximum test value (resistance) is set to 0.100 Ω .

Error If <data> is other than numerical value described above, an execution error occurs.
The execution of this command in a state other than the READY state causes an execution error.

:CONFigure:RUPPer?

■ Queries the maximum test value (resistance).

Syntax :CONFigure:RUPPer?

Function Returns the maximum test value (resistance) setting as a numerical value in NR2 format.

<data> Numerical data in NR2 format between 0.000 and 2.000

Example Response
If headers are on :CONFIGURE:RUPPER 0.200
If headers are off 0.200

Error If the response message is longer than 300 bytes, a query error is generated.

:CONFigure:TIMer

- Sets the test time.

Syntax :CONFigure:TIMer_<data>

<data> Numerical data in NR1 or NR2 format between 0.5 and 999

Function Sets the test time.
The numerical value can be in NRf format, but rounding is performed for figures beyond the last valid decimal place.

Note The test time can be used as the basis for the test only when the endless timer function setting is disabled and when "ON" is selected in the ON/OFF setting for the test time.

Example Transmission :CONFigure:TIMer 60.0
The test time is set to 60.0 s.

Error If <data> is other than numerical value described above, an execution error occurs.
The execution of this command in a state other than the READY state causes an execution error.

:CONFigure:TIMer?

- Queries the test time.

Syntax :CONFigure:TIMer?

Function Returns the test time setting as a numerical value in NR1 or NR2 format.

<data> Numerical data in NR1 or NR2 format between 0.5 and 999

Example Response
If headers are on :CONFIGURE:TIMER 60.0
If headers are off 60.0

Error If the response message is longer than 300 bytes, a query error is generated.

:CONFigure:VLOWer

■ Sets the minimum test value (voltage).

Syntax :CONFigure:VLOWer_<data>

<data> Numerical data in NR2 format between 0.00 and 6.00

Function Sets the minimum test value (voltage).
The numerical value can be in NRf format, but rounding is performed for figures beyond the last valid decimal place.

Note The minimum test value (voltage) can be used as the basis for the test only when the maximum and minimum test values are set to be expressed in "VOLT" (voltage) and when the minimum test value setting is not disabled, and when "ON" is selected in the ON/OFF setting for the minimum test value.

Example Transmission :CONFigure:VLOWer 0.00
The minimum test value (voltage) is set to 0.00 V.

Error If <data> is other than numerical value described above, an execution error occurs.
The execution of this command in a state other than the READY state causes an execution error.

:CONFigure:VLOWer?

■ Queries the minimum test value (voltage).

Syntax :CONFigure:VLOWer?

Function Returns the minimum test value (voltage) setting as a numerical value in NR2 format.

<data> Numerical data in NR2 format between 0.00 and 6.00

Example Response
If headers are on :CONFigure:VLOWer 0.00
If headers are off 0.00

Error If the response message is longer than 300 bytes, a query error is generated.

:CONFigure:VUPPer

- Sets the maximum test value (voltage).

Syntax :CONFigure:VUPPer_<data>

<data> Numerical data in NR2 format between 0.00 and 6.00

Function Sets the maximum test value (voltage).
The numerical value can be in NRf format, but rounding is performed for figures beyond the last valid decimal place.

Note The maximum test value (voltage) can be used as the basis for the test only when the maximum and minimum test values are set to be expressed in "VOLT" (voltage) and when "ON" is selected in the ON/OFF setting for the maximum test value.

Example Transmission :CONFigure:VUPPer 2.50
The maximum test value (voltage) is set to 2.50 V.

Error If <data> is other than numerical value described above, an execution error occurs.
The execution of this command in a state other than the READY state causes an execution error.

:CONFigure:VUPPer?

- Queries the maximum test value (voltage).

Syntax :CONFigure:VUPPer?

Function Returns the maximum test value (voltage) setting as a numerical value in NR2 format.

<data> Numerical data in NR2 format between 0.00 and 6.00

Example Response
If headers are on :CONFigure:VUPPER 2.50
If headers are off 2.50

Error If the response message is longer than 300 bytes, a query error is generated.

:ESR0?

- Queries event status register 0.

Syntax ESR0?

Function Returns the value of event status register 0 (ESR0) as a numerical value in NR1 format between 0 and 255, and then clears event status register 0. No header is prefixed to the response message.

128	64	32	16	8	4	2	1
bit 7	bit 6	bit 5	bit 4	bit 3	bit 2	bit 1	bit 0
Unused	Unused	Unused	Unused	EOM	LFAIL	UFAIL	PASS

Event status register 0 (ESR0)

Example Response 4
Bit 2 of ESR0 has been set to 1.

Error If the response message is longer than 300 bytes, a query error is generated.

:HEADer

- Enables and disables headers for the response messages.

Syntax :HEADer_<data>

<data> ON/OFF (character data)

Function Sets whether or not the 3157 will prefix headers to its response messages. When powering on, <data> is initially set to OFF.

Example Transmission :HEADer ON
Headers are prefixed to response messages.

Error If <data> is other than character data described above, an execution error occurs.

:HEADer?

- Queries whether or not headers on response messages are enabled.

Syntax :HEADer?

Function Returns whether or not headers on response messages are enabled as character data.

<data> ON/OFF (character data)

Example Response
If headers are on :HEADer ON
If headers are off OFF

Error If the response message is longer than 300 bytes, a query error is generated.

:KEY

■ Sets key entry.

Syntax :KEY_<data 1>, <data 2>

<data 1> Numerical data in NR1 format between 0 and 1

<data 2> Numerical data in NR1 format of 1, 2, 4, 8, 16, 32, 64 to 66, 68, 72, 80, 96, 128

Function Sets the key registers 0 and 1 (KEY0 and KEY1).

<data 1>

128	64	32	16	8	4	2	1
bit 7	bit 6	bit 5	bit 4	bit 3	bit 2	bit 1	bit 0

Unused	Unused	Unused	Unused	Unused	Unused	Unused	STOP
--------	--------	--------	--------	--------	--------	--------	------

Key register 0 (KEY0)

<data 2>

128	64	32	16	8	4	2	1
bit 7	bit 6	bit 5	bit 4	bit 3	bit 2	bit 1	bit 0

START	SHIFT	0 ADJ	ON/OFF	DOWN	UP	RIGHT	LEFT
-------	-------	-------	--------	------	----	-------	------

Key register 1 (KEY1)

Note Whether key entry is possible or not depends on the state of the unit. For more information, see the instruction manual for the 3157.

Example Transmission :KEY 0,2
The right arrow key entry is set.

Error If <data 1> and <data 2> are other than numerical values described above, an execution error occurs.

:LOWer

■ Enables and disables the minimum test value.

Syntax :LOWer_<data>

<data> ON/OFF (character data)

Function Enables and disables the minimum test value.

Note When the minimum test value setting is disabled, the ON/OFF setting for the minimum test value is not reflected in the test.

Example Transmission :LOWer ON
The minimum test value is set to ON.

Error If <data> is other than character data and numerical value described above, a command error occurs.

The execution of this command in a state other than the following states causes an execution error:

- READY state
- Optional function setting screen

:LOWer?

- Queries the minimum test value enablement.

Syntax :LOWer?

Function Returns the current enablement state of the minimum test value as character data.

<data> ON/OFF (character data)

Example Response
If headers are on :LOWER ON
If headers are off ON

Error If the response message is longer than 300 bytes, a query error is generated.

:MEASure:CURRent?

- Queries the measured current value.

Syntax :MEASure:CURRent?

Function Returns the measured current value as a numerical value in NR2 format.

<data> Numerical data in NR2 format between 0.0 and 35.0

Note The measured current value is returned in the TEST state (test in progress), and the result of the previous test is returned in the other states.

In the stand-by state (as indicated by a blinking **TEST** lamp), the following values are returned.

In the soft start mode: Measured value

In the continuous test mode: Result of the previous test

Example Response
If headers are on :MEASURE:CURRENT 25.0
If headers are off 25.0

Error If the response message is longer than 300 bytes, a query error is generated.

:MEASure:RESistance?

■ Queries the measured resistance value.

- Syntax** :MEASure:RESistance?
- Function** Returns the measured resistance value as a numerical value in NR2 format.
- <data>** O.F. (character data)
Numerical data in NR2 format between 0.000 and 2.000
- Note** The measured current value is returned in the TEST state (test in progress), and the result of the previous test is returned in the other states.
In the stand-by state (as indicated by a blinking **TEST** lamp), the following values are returned.
In the soft start mode: Measured value
In the continuous test mode: Result of the previous test
In the case of an overflow for the measured resistance, "O.F." is returned.
- Example** Response
If headers are on :MEASURE:RESISTANCE 0.200
If headers are off 0.200
- Error** If the response message is longer than 300 bytes, a query error is generated.

:MEASure:TIMer?

■ Queries the test time elapsed.

- Syntax** :MEASure:TIMer?
- Function** Returns the test time elapsed as a numerical value in NR2 format.
- <data>** --- (character data)
Numerical data in NR2 format between 0.0 and 999.0
- Note** The measured current value is returned in the TEST state (test in progress), and the result of the previous test is returned in the other states.
The test time elapsed is returned regardless of the ON/OFF setting for the test time. Thus, the value displayed on the GP-IB interface may differ from that displayed on the main body.
The test time elapsed is returned regardless of the ON/OFF setting for the test time. However, when the endless timer function is set, "---" is returned.
In the stand-by state (as indicated by a blinking **TEST** lamp), the following values are returned.
In the soft start mode: Measured value
In the continuous test mode: Result of the previous test
- Example** Response
If headers are on :MEASURE:TIMER 10.0
If headers are off 10.0
- Error** If the response message is longer than 300 bytes, a query error is generated.

:MEASure:VOLTage?

- Queries the measured voltage value.

Syntax :MEASure:VOLTage?

Function Returns the measured voltage value as a numerical value in NR2 format.

<data> Numerical data in NR2 format between 0.00 and 6.00

Note The measured current value is returned in the TEST state (test in progress), and the result of the previous test is returned in the other states. In the stand-by state (as indicated by a blinking **TEST** lamp), the following values are returned.
In the soft start mode: Measured value
In the continuous test mode: Result of the previous test

Example Response
If headers are on :MEASURE:VOLTAGE 2.50
If headers are off 2.50

Error If the response message is longer than 300 bytes, a query error is generated.

:MEASure:RESult:VOLTage?

- Queries the measured value and result (voltage).

Syntax :MEASure:RESult:VOLTage?

Function Returns as data the measured value and result as <measured current value>, <measured voltage value>, <test time elapsed>, <screening result> in order. If the unit of the maximum and minimum test values is set to "OHM" (resistance), the measured voltage value and screening result are OFF.

<data> Measured current and voltage values: Numerical value in NR2 format
Test time elapsed: --- (character data) or numerical value in NR2 format
Screening results: PASS, UFAIL (UPPER FAIL), LFAIL (LOWER FAIL), ULFAIL (FAIL due to the protection function), OFF (other than PASS and FAIL) (character data)

Note The previous measured value and result are returned until the next test is completed.
If the measured resistance value is required, query using the ":MEASure:RESistance?" command until the next test starts.
The test time elapsed is returned regardless of the ON/OFF setting for the test time. However, when the endless timer function is set, "---" is returned.

Example Response
If headers are on :MEASURE:RESULT:VOLTAGE 25.0,2.50,60.0,PASS
If headers are off 25.0,2.50,60.0,PASS

Error If the response message is longer than 300 bytes, a query error is generated.

:MEASure:RESult:RESistance?

- Queries the measured value and result (resistance).

Syntax	:MEASure:RESult:RESistance?
Function	Returns as data the measured value and result as <measured current value>, <measured resistance value>, <test time elapsed>, <screening result> in order. If the unit of the maximum and minimum test values is set to "VOLT" (voltage), the measured resistance value and screening result are OFF.
<data>	Measured current value: Numerical value in NR2 format Measured resistance value: O.F. (character data) or numerical value in NR2 format Test time elapsed: --- (character data) or numerical value in NR2 format Screening results: PASS, UFAIL (UPPER FAIL), LFAIL (LOWER FAIL), ULFAIL (FAIL due to the protection function), OFF (other than PASS and FAIL) (character data)
Note	The previous measured value and result are returned until the next test is completed. If the measured voltage value is required, query using the ":MEASure:VOLTage?" command until the next test starts. In the case of an overflow for the measured resistance, "O.F." is returned. The test time elapsed is returned regardless of the ON/OFF setting for the test time. However, when the endless timer function is set, "---" is returned.
Example	Response If headers are on :MEASURE:RESULT:RESISTANCE 25.0,0.100,60.0,PASS If headers are off 25.0,0.100,60.0,PASS
Error	If the response message is longer than 300 bytes, a query error is generated.

:MEMory:CLEar

- Clears Setting memory.

Syntax	:MEMory:CLEar_<data>
<data>	Numerical data in NR1 format between 1 and 20
Function	Clears Setting memory numbered <data>. The numerical value can be in NRf format, but any digits after the decimal point will be rounded.
Note	The specified Setting memory is initialized. For the items which are initialized, see the "*RST" command.
Example	Transmission :MEMory:CLEar 10 Setting memory numbered 10 is cleared.
Error	If <data> is other than numerical value described above, an execution error occurs. The execution of this command in a state other than the READY state causes an execution error.

:MEMory:FILE?

- Queries the contents of Setting memory.

Syntax	:MEMory:FILE?_<data 1>
<data 1>	Numerical data in NR1 format between 1 and 20
Function	Returns as data (<data2>) the contents of Setting memory numbered <data 1> as <output current value>, <maximum test value>, <minimum test value>, <test time> in order. If the unit of the maximum and minimum test values is set to "OHM" (resistance), the maximum and minimum test values are expressed as resistance values. If the unit of the maximum and minimum test values is set to "VOLT" (voltage), the maximum and minimum test values are expressed as voltage values.
<data 2>	Output current value: Numerical value in NR2 format Maximum test value, minimum test value, test time: OFF, --- (character data), or numerical value in NR2 format When the minimum test value is not set, returns "---." When the minimum test value is set and set to OFF, returns "OFF." When the endless timer function is set, returns "---." When the endless timer function is not set, and the test time is set to OFF, returns "OFF."
Example	Transmission :MEMory:FILE? 1 Response If headers are on :MEMORY:FILE 25.0,0.100,0.000,60.0 If headers are off 25.0,0.100,0.000,60.0
Error	If the response message is longer than 300 bytes, a query error is generated. The execution of this command in a state other than the READY state causes an execution error.

:MEMory:LOAD

- Loads Setting memory.

Syntax	:MEMory:LOAD_<data>
<data>	Numerical data in NR1 format between 1 and 20
Function	Loads Setting memory numbered <data>. The numerical value can be in NRf format, but any digits after the decimal point will be rounded.
Example	Transmission :MEMory:LOAD 10 Setting memory numbered 10 is loaded.
Error	If <data> is other than numerical value described above, an execution error occurs. The execution of this command in a state other than the READY state causes an execution error.

:MEMory:SAVE

- Saves in Setting memory.

Syntax	:MEMory:SAVE_<data>
<data>	Numerical data in NR1 format between 1 and 20
Function	Saves the current settings in Setting memory numbered <data>. The numerical value can be in NRf format, but any digits after the decimal point will be rounded.
Example	Transmission :MEMory:SAVE 10 The current settings are saved in Setting memory numbered 10.
Error	If <data> is other than numerical value described above, an execution error occurs. The execution of this command in a state other than the READY state causes an execution error.

:START

- Starts a test.

Syntax	:START
Function	Starts a test in the READY state (except the optional function setting screen).
Note	The ":START" command works in a state in which the momentary OUT settings are disabled even though the momentary OUT settings have been set.
Example	Transmission :START
Error	The execution of this command in a state other than the READY state causes an execution error. If the data parameters are set after this command, a command error occurs.

:STATE?

- Queries the state.

Syntax	:STATE?
Function	Returns the state as data.
<data>	Screening results: PASS, UFAIL, LFAIL, ULFAIL, READY, TEST, OFF (character data) PASS: PASS state UFAIL: FAIL state (UPPER FAIL) LFAIL: FAIL state (LOWER FAIL) ULFAIL: FAIL state (FAIL due to the protection function) OFF: Hold state (in a state other than the PASS and FAIL states), save screen, load screen, optional function setting screen
Example	Response If headers are on :STATE PASS If headers are off PASS
Error	If the response message is longer than 300 bytes, a query error is generated.

:STOP

- Performs forcible ending of a test and releases the hold state.

Syntax :STOP

Function In the TEST state (test in progress), performs forcible ending of a test. When retaining the test result, returns to the READY state.
In the save screen, returns to the READY state without saving.
In the load screen, returns to the READY state without loading.

Example Transmission :STOP

Error If the data parameters are set after this command, a command error occurs.

:SYSTem:ERRor?

- Queries RS-232C communication condition errors.

Syntax :ERRor?

Function Returns the value of RS-232C communication condition errors as a numerical value in NR1 format from 0 to 7, and then clears RS-232C communication condition errors.
No header is prefixed to the response message.

<data> Numerical data in NR1 format between 0 and 7

Example Response 4
An overrun error has occurred.

128	64	32	16	8	4	2	1
bit 7	bit 6	bit 5	bit 4	bit 3	bit 2	bit 1	bit 0
Unused	Unused	Unused	Unused	Unused	Overrun error	Framing error	Parity error

RS-232C communication condition errors register

Error If the response message is longer than 300 bytes, a query error is generated.

:SYSTem:OPTion:BUZZer

■ Sets the buzzer.

Syntax :SYSTem:OPTion:BUZZer_<data>

<data> Numerical data in NR1 format between 0 and 3

Function Sets the buzzer.

- 1: ON at screening, ON at error
- 2: OFF at screening, OFF at error
- 3: OFF at screening, ON at error
- 4: ON at screening, OFF at error

The numerical value can be in NRf format, but any digits after the decimal point will be rounded.

Example Transmission :SYSTem:OPTion:BUZZer 3
The buzzer is set to ON at screening, OFF at error.

Error If <data> is other than numerical value described above, an execution error occurs.

The execution of this command in a state other than the following states causes an execution error:

- READY state
- Optional function setting screen

:SYSTem:OPTion:BUZZer?

■ Queries the buzzer.

Syntax :SYSTem:OPTion:BUZZer?

Function Returns the buzzer setting as a numerical value in NR1 format.

<data> Numerical data in NR1 format between 0 and 3

Example Response

If headers are on :SYSTEM:OPTION:BUZZER 3

If headers are off 3

Error If the response message is longer than 300 bytes, a query error is generated.

:SYSTem:OPTion:CCHange

- Sets the current changeability in the TEST state.

Syntax :SYSTem:OPTion:CCHange_<data>

<data> Numerical data in NR1 format between 0 and 1

Function Sets the current changeability in the TEST state.

0: Not changeable

1: Changeable

The numerical value can be in NRf format, but any digits after the decimal point will be rounded.

Example Transmission :SYSTem:OPTion:CCHange 1

The current changeability in the TEST state is set to "Changeable."

Error If <data> is other than numerical value described above, an execution error occurs.

The execution of this command in a state other than the following states causes an execution error:

- READY state
- Optional function setting screen

:SYSTem:OPTion:CCHange?

- Queries the current changeability in the TEST state.

Syntax :SYSTem:OPTion:CCHange?

Function Returns the setting for the current changeability in the TEST state as a numerical value in NR1 format.

<data> Numerical data in NR1 format between 0 and 1

Example Response

If headers are on :SYSTEM:OPTION:CCHANGE 1

If headers are off 1

Error If the response message is longer than 300 bytes, a query error is generated.

:SYSTem:OPTion:CDATa

- Sets the maximum number of test data in the test data count function.

Syntax	:SYSTem:OPTion:CDATa_<data>
<data>	Numerical data in NR1 format between 1 and 99
Function	Sets the maximum number of test data in the test data count function. The numerical value can be in NRf format, but any digits after the decimal point will be rounded.
Note	When the test data count function is not set, the setting for the maximum number of test data is not reflected in the test.
Example	Transmission :SYSTem:OPTion:CDATa 10 The maximum number of test data is set to 10.
Error	If <data> is other than numerical value described above, an execution error occurs. If a smaller value than that set for the number of test data is set, an execution error occurs. The execution of this command in a state other than the following states causes an execution error: <ul style="list-style-type: none"> • READY state • Optional function setting screen

:SYSTem:OPTion:CDATa?

- Queries the maximum number of test data in the test data count function.

Syntax	:SYSTem:OPTion:CDATa?
Function	Returns the setting for the maximum number of test data in the test data count function as a numerical value in NR1 format.
<data>	Numerical data in NR1 format between 1 and 99
Example	Response If headers are on :SYSTEM:OPTION:CDATA 10 If headers are off 10
Error	If the response message is longer than 300 bytes, a query error is generated.

:SYSTem:OPTion:COUNT

■ Sets the test data count function.

Syntax :SYSTem:OPTion:COUNT_<data>

<data> Numerical data in NR1 format between 0 and 1

Function Sets the test data count function.

0: Not set

1: Set

The numerical value can be in NRf format, but any digits after the decimal point will be rounded.

Note When the test data count function is not set, the setting for the maximum number of test data is not reflected in the test.

Example Transmission :SYSTem:OPTion:COUNT 1
The test data count function is set.

Error If <data> is other than numerical value described above, an execution error occurs.

The execution of this command in a state other than the following states causes an execution error:

- READY state
- Optional function setting screen

:SYSTem:OPTion:COUNT?

■ Queries the test data count function.

Syntax :SYSTem:OPTion:COUNT?

Function Returns the test data count function setting as a numerical value in NR1 format.

<data> Numerical data in NR1 format between 0 and 1

Example Response

If headers are on :SYSTEM:OPTION:COUNT 1

If headers are off 1

Error If the response message is longer than 300 bytes, a query error is generated.

:SYSTem:OPTion:ENDLess

■ Sets the endless timer function.

Syntax :SYSTem:OPTion:ENDLess_<data>

<data> Numerical data in NR1 format between 0 and 1

Function Sets the endless timer function.

0: Not set

1: Set

The numerical value can be in NRf format, but any digits after the decimal point will be rounded.

Note When the endless timer function is set, the ON/OFF setting for the test time is not reflected in the test.

Example Transmission :SYSTem:OPTion:ENDLess 1
The endless timer function is set.

Error If <data> is other than numerical value described above, an execution error occurs.

The execution of this command in a state other than the following states causes an execution error:

- READY state
- Optional function setting screen

:SYSTem:OPTion:ENDLess?

■ Queries the endless timer function.

Syntax :SYSTem:OPTion:ENDLess?

Function Returns the endless timer function setting as a numerical value in NR1 format.

<data> Numerical data in NR1 format between 0 and 1

Example Response
If headers are on :SYSTEM:OPTION:ENDLESS 1
If headers are off 1

Error If the response message is longer than 300 bytes, a query error is generated.

:SYSTem:OPTion:FREQuency

■ Sets the output current frequency.

Syntax :SYSTem:OPTion:FREQuency_<data>

<data> Numerical data in NR1 format between 0 and 1

Function Sets the output current frequency.

0: 50 Hz

1: 60 Hz

The numerical value can be in NRf format, but any digits after the decimal point will be rounded.

Example Transmission :SYSTem:OPTion:FREQuency 1
The output current frequency is set to 60 Hz.

Error If <data> is other than numerical value described above, an execution error occurs.

The execution of this command in a state other than the following states causes an execution error:

- READY state
- Optional function setting screen

:SYSTem:OPTion:FREQuency?

■ Queries the output current frequency.

Syntax :SYSTem:OPTion:FREQuency?

Function Returns the output current frequency setting as a numerical value in NR1 format.

<data> Numerical data in NR1 format between 0 and 1

Example Response

If headers are on :SYSTEM:OPTION:FREQUENCY 1

If headers are off 1

Error If the response message is longer than 300 bytes, a query error is generated.

:SYSTem:OPTion:HOLD

■ Sets the hold function.

- Syntax** :SYSTem:OPTion:HOLD_<data>
- <data>** Numerical data in NR1 format between 0 and 1
- Function** Sets the hold function.
0: Not held
1: Held
The numerical value can be in NRf format, but any digits after the decimal point will be rounded.
- Example** Transmission :SYSTem:OPTion:HOLD 1
The hold function is set to "Held."
- Error** If <data> is other than numerical value described above, an execution error occurs.
The execution of this command in a state other than the following states causes an execution error:
- READY state
 - Optional function setting screen

:SYSTem:OPTion:HOLD?

■ Queries the hold function.

- Syntax** :SYSTem:OPTion:HOLD?
- Function** Returns the hold function setting as a numerical value in NR1 format.
- <data>** Numerical data in NR1 format between 0 and 1
- Example** Response
If headers are on :SYSTEM:OPTION:HOLD 1
If headers are off 1
- Error** If the response message is longer than 300 bytes, a query error is generated.

:SYSTem:OPTion:LOWer

■ Sets the minimum test value.

Syntax :SYSTem:OPTion:LOWer_<data>

<data> Numerical data in NR1 format between 0 and 1

Function Sets the minimum test value.

0: Not set

1: Set

The numerical value can be in NRf format, but any digits after the decimal point will be rounded.

Note The ":STARt" command works in a state in which the momentary OUT settings are disabled even though the momentary OUT settings have been set.

Example Transmission :SYSTem:OPTion:LOWer 1
The minimum test value is set.

Error If <data> is other than numerical value described above, an execution error occurs.

The execution of this command in a state other than the following states causes an execution error:

- READY state
- Optional function setting screen

:SYSTem:OPTion:LOWer?

■ Queries the minimum test value.

Syntax :SYSTem:OPTion:LOWer?

Function Returns the minimum test value setting as a numerical value in NR1 format.

<data> Numerical data in NR1 format between 0 and 1

Example Response

If headers are on :SYSTEM:OPTION:LOWER 1

If headers are off 1

Error If the response message is longer than 300 bytes, a query error is generated.

:SYSTem:OPTion:MOMentary

■ Sets the momentary OUT function.

Syntax :SYSTem:OPTion:MOMentary_<data>

<data> Numerical data in NR1 format between 0 and 1

Function Sets the momentary OUT function.

0: Not set

1: Set

The numerical value can be in NRf format, but any digits after the decimal point will be rounded.

Note The ":START" command works in a state in which the momentary OUT settings are disabled even though the momentary OUT settings have been set.

Example Transmission :SYSTem:OPTion:MOMentary 1
The momentary OUT function is set.

Error If <data> is other than numerical value described above, an execution error occurs.

In the continuous test mode, setting the momentary OUT function causes an execution error.

The execution of this command in a state other than the following states causes an execution error:

- READY state
- Optional function setting screen

:SYSTem:OPTion:MOMentary?

■ Queries the momentary OUT function.

Syntax :SYSTem:OPTion:MOMentary?

Function Returns the momentary OUT function setting as a numerical value in NR1 format.

<data> Numerical data in NR1 format between 0 and 1

Example Response

If headers are on :SYSTEM:OPTION:MOMENTARY 1

If headers are off 1

Error If the response message is longer than 300 bytes, a query error is generated.

:SYSTem:OPTion:PFHold

■ Sets the PASS/FAIL hold function.

Syntax :SYSTem:OPTion:PFHold_<data>

<data> Numerical data in NR1 format between 0 and 3

Function Sets the PASS/FAIL hold function.

0: PASS not held, FAIL held

1: PASS held, FAIL held

2: PASS not held, FAIL not held

3: PASS held, FAIL not held

The numerical value can be in NRf format, but any digits after the decimal point will be rounded.

Example Transmission :SYSTem:OPTion:PFHold 3

The PASS/FAIL hold function is set to "PASS held, FAIL not held."

Error If <data> is other than numerical value described above, an execution error occurs.

The execution of this command in a state other than the following states causes an execution error:

- READY state
- Optional function setting screen

:SYSTem:OPTion:PFHold?

■ Queries the PASS/FAIL hold function.

Syntax :SYSTem:OPTion:PFHold?

Function Returns the PASS/FAIL hold function setting as a numerical value in NR1 format.

<data> Numerical data in NR1 format between 0 and 3

Example Response

If headers are on :SYSTEM:OPTION:PFHOLD 3

If headers are off 3

Error If the response message is longer than 300 bytes, a query error is generated.

:SYSTem:OPTion:PRINter

■ Sets the printer output function.

- Syntax** :SYSTem:OPTion:PRINter_<data>
- <data>** Numerical data in NR1 format between 0 and 2
- Function** Sets the printer output function.
0: Not used
1: Automatically print for PASS/FAIL screening.
2: Print selectively when the PASS/FAIL state is held.
The numerical value can be in NRf format, but any digits after the decimal point will be rounded.
- Example** Transmission :SYSTem:OPTion:PRINter 0
The printer output function is set to "Not used."
- Error** If <data> is other than numerical value described above, an execution error occurs.
The execution of this command in a state other than the following states causes an execution error:
- READY state
 - Optional function setting screen

:SYSTem:OPTion:PRINter?

■ Queries the printer output function.

- Syntax** :SYSTem:OPTion:PRINter?
- Function** Returns the printer output function setting as a numerical value in NR1 format.
- <data>** Numerical data in NR1 format between 0 and 2
- Example** Response
If headers are on :SYSTEM:OPTION:PRINTER 0
If headers are off 0
- Error** If the response message is longer than 300 bytes, a query error is generated.

:SYSTem:OPTion:TMODe

■ Sets the test mode.

Syntax :SYSTem:OPTion:TMODe_<data>

<data> Numerical data in NR1 format between 0 and 2

Function Sets the test mode.

0: Soft start mode

1: Normal mode

2: Continuous test mode

The numerical value can be in NRf format, but any digits after the decimal point will be rounded.

Note When the momentary OUT function is set, if the continuous test mode is set, the momentary OUT function is automatically set to "Not set."

Example Transmission :SYSTem:OPTion:TMODe 2
The test mode is set to Continuous test mode.

Error If <data> is other than numerical value described above, an execution error occurs.

The execution of this command in a state other than the following states causes an execution error:

- READY state
- Optional function setting screen

:SYSTem:OPTion:TMODe?

■ Queries the test mode.

Syntax :SYSTem:OPTion:TMODe?

Function Returns the test mode setting as a numerical value in NR1 format.

<data> Numerical data in NR1 format between 0 and 2

Example Response

If headers are on :SYSTEM:OPTION:TMODE 2

If headers are off 2

Error If the response message is longer than 300 bytes, a query error is generated.

:TImEr

- Enables and disables the test time.

Syntax :TImEr_<data>

<data> ON/OFF (character data)

Function Enables and disables the test time.

Note When the endless timer function is set, the ON/OFF setting for the test time is not reflected in the test.

Example Transmission :TImEr ON
The test time is set to ON.

Error If <data> is other than character data and numerical value described above, a command error occurs.
The execution of this command in a state other than the following states causes an execution error:

- READY state
- Optional function setting screen

:TImEr?

- Queries the test time enablement.

Syntax :TImEr?

Function Returns the current enablement state of the test time as character data.

<data> ON/OFF (character data)

Example Response
If headers are on :TImEr ON
If headers are off ON

Error If the response message is longer than 300 bytes, a query error is generated.

:UNIT

■ Sets the unit of the maximum and minimum test values.

Syntax :UNIT_<data>

<data> OHM: resistance (character data)
VOLT: voltage (character data)

Function Sets the unit of the maximum and minimum test values.

Note If the unit of the maximum and minimum test values is set to "OHM" (resistance), the maximum and minimum test values (resistance) settings are reflected in the test.
If the unit of the maximum and minimum test values is set to "VOLT" (voltage), the maximum and minimum test values (voltage) settings are reflected in the test.

Example Transmission :UNIT OHM
The unit of the maximum and minimum test values is set to OHM.

Error If <data> is other than character data and numerical value described above, a command error occurs.
The execution of this command in a state other than the following states causes an execution error:

- READY state
- Optional function setting screen

:UNIT?

■ Queries the unit of the maximum and minimum test values.

Syntax :UNIT?

Function Returns the setting for the unit of the maximum and minimum test values as character data.

<data> OHM/VOLT (character data)

Example Response
If headers are on :UNIT OHM
If headers are off OHM

Error If the response message is longer than 300 bytes, a query error is generated.

:UPPer

- Enables and disables the maximum test value.

Syntax :UPPer_<data>

<data> ON/OFF (character data)

Function Enables and disables the maximum test value.

Example Transmission :UPPer ON
The maximum test value is set to ON.

Error If <data> is other than character data and numerical value described above, a command error occurs.

The execution of this command in a state other than the following states causes an execution error:

- READY state
- Optional function setting screen

:UPPer?

- Queries the maximum test value enablement.

Syntax :TImEr?

Function Returns the current enablement state of the maximum test value as character data.

<data> ON/OFF (character data)

Example Response
If headers are on :UPPER ON
If headers are off ON

Error If the response message is longer than 300 bytes, a query error is generated.

5.5 Response Format for Queries as Numerical Value

The response formats are as follows.

- (1) Output current value and measured current value

.

.

Two or three digits (in NR2 format)

- (2) Maximum test value (voltage), minimum test value (voltage) and measured voltage value

.

Three digits (in NR2 format)

- (3) Maximum test value (resistance), minimum test value (resistance) and measured resistance value

.

Four digits (in NR2 format)

- (4) Test time and test time elapsed

.

.

.

Two, three or four digits (in NR2 format)

- (5) Number of test data

One or two digits (in NR1 format)

5.6 Initialization Items

The following table shows which items are initialized and which not, under various conditions.

Initialization method Item	Powering on	*RST command	*CLS command
RS-232C communication conditions	—	—	—
Device specific functions (ranges etc.) *1	—	●	—
Output queue	●	—	—
Input buffer	●	—	—
Event registers	●*2	—	●
Current path	●	—	—
Headers on/off	●	●	—
Measurement resister	●	●	—

*1: When the power is turned on, item is discriminated.

*2: Except the PON bit (bit 7)

Chapter 6

Troubleshooting

If the RS-232C appears to be malfunctioning, refer to the information below before calling for servicing.

Symptom	Cause / Treatment
The RS-232C has stopped working completely.	Are the cables properly connected?
	Are all the devices powered on?
	Has the communication condition been correctly set?
Although a command has been transmitted, nothing has happened.	Using the "*ESR?" query, inspect the standard event status register, and check what type of error has occurred.
	Using the ":SYSTem:ERRor?" query, and check whether transmission error occurred on the RS-232C.
Sending several queries, produces only one response.	Has an error occurred?
	Send the queries one at a time, and read the responses individually. When you want to read them in all at once, try doing so by putting them all on one line separated by the message separator character.
The response message to a query differs from the display on the front panel of the 3157.	Due to the response message being produced at the instant that the 3157 receives the query, there is a possibility that it may not agree with the display at the instant that the controller reads it in.

Service

If damage is suspected, read the "Troubleshooting" section to remedy the problem.

If this does not help you, contact your authorized Hioki distributor or reseller.

Warranty Certificate

HIOKI

Model	Serial number	Warranty period Three (3) years from date of purchase (___ / ___)
-------	---------------	--

Customer name: _____
Customer address: _____

Important

- Please retain this warranty certificate. Duplicates cannot be reissued.
- Complete the certificate with the model number, serial number, and date of purchase, along with your name and address. The personal information you provide on this form will only be used to provide repair service and information about Hioki products and services.

This document certifies that the product has been inspected and verified to conform to Hioki's standards. Please contact the place of purchase in the event of a malfunction and provide this document, in which case Hioki will repair or replace the product subject to the warranty terms described below.

Warranty terms

1. The product is guaranteed to operate properly during the warranty period (three [3] years from the date of purchase). If the date of purchase is unknown, the warranty period is defined as three (3) years from the date (month and year) of manufacture (as indicated by the first four digits of the serial number in YYMM format).
2. If the product came with an AC adapter, the adapter is warranted for one (1) year from the date of purchase.
3. The accuracy of measured values and other data generated by the product is guaranteed as described in the product specifications.
4. In the event that the product or AC adapter malfunctions during its respective warranty period due to a defect of workmanship or materials, Hioki will repair or replace the product or AC adapter free of charge.
5. The following malfunctions and issues are not covered by the warranty and as such are not subject to free repair or replacement:
 - 1. Malfunctions or damage of consumables, parts with a defined service life, etc.
 - 2. Malfunctions or damage of connectors, cables, etc.
 - 3. Malfunctions or damage caused by shipment, dropping, relocation, etc., after purchase of the product
 - 4. Malfunctions or damage caused by inappropriate handling that violates information found in the instruction manual or on precautionary labeling on the product itself
 - 5. Malfunctions or damage caused by a failure to perform maintenance or inspections as required by law or recommended in the instruction manual
 - 6. Malfunctions or damage caused by fire, storms or flooding, earthquakes, lightning, power anomalies (involving voltage, frequency, etc.), war or unrest, contamination with radiation, or other acts of God
 - 7. Damage that is limited to the product's appearance (cosmetic blemishes, deformation of enclosure shape, fading of color, etc.)
 - 8. Other malfunctions or damage for which Hioki is not responsible
6. The warranty will be considered invalidated in the following circumstances, in which case Hioki will be unable to perform service such as repair or calibration:
 - 1. If the product has been repaired or modified by a company, entity, or individual other than Hioki
 - 2. If the product has been embedded in another piece of equipment for use in a special application (aerospace, nuclear power, medical use, vehicle control, etc.) without Hioki's having received prior notice
7. If you experience a loss caused by use of the product and Hioki determines that it is responsible for the underlying issue, Hioki will provide compensation in an amount not to exceed the purchase price, with the following exceptions:
 - 1. Secondary damage arising from damage to a measured device or component that was caused by use of the product
 - 2. Damage arising from measurement results provided by the product
 - 3. Damage to a device other than the product that was sustained when connecting the device to the product (including via network connections)
8. Hioki reserves the right to decline to perform repair, calibration, or other service for products for which a certain amount of time has passed since their manufacture, products whose parts have been discontinued, and products that cannot be repaired due to unforeseen circumstances.

HIOKI E.E. CORPORATION

<http://www.hioki.com>

18-07 EN-3

HIOKI
www.hioki.com/



**All regional
contact
information**

HEADQUARTERS

81 Koizumi
Ueda, Nagano 386-1192 Japan

HIOKI EUROPE GmbH

Helfmann-Park 2
65760 Eschborn, Germany
hioki@hioki.eu

2111 EN

Edited and published by HIOKI E.E. CORPORATION

Printed in Japan

- CE declarations of conformity can be downloaded from our website.
- Contents subject to change without notice.
- This document contains copyrighted content.
- It is prohibited to copy, reproduce, or modify the content of this document without permission.
- Company names, product names, etc. mentioned in this document are trademarks or registered trademarks of their respective companies.