

HIOKI

3930

Instruction Manual

HIGH VOLTAGE SCANNER

EN

Jan. 2020 Revised edition 5
3930A981-05 20-01H



Contents

Introduction	i
Inspection	i
Safety Notes	ii
Notes on Use	iv
Chapter Summary	v
Chapter 1 Overview	1
1.1 Product Introduction	1
1.2 Features	2
1.3 Names and Functions of Parts	3
1.3.1 Front panel	3
1.3.2 Rear panel	4
1.3.3 9615-01, 9615-02 H.V. TEST LEAD (Accessories)	5
1.4 External Dimensions	6
Chapter 2 Testing Arrangements	7
2.1 Terms	7
2.2 Installation of the Unit	10
2.3 Connection	11
2.3.1 Connecting the Protective Conductor Terminal	11
2.3.2 Setting the Mode	12
2.3.3 Setting the ID	12
2.3.4 Control Connector Connection	13
2.3.5 High-voltage Input Cord and H.V. TEST LEAD Connection	14
2.3.6 Powering On and Off the Unit	15
2.4 Startup Inspection	16

Chapter 3 Control Signal and Control Method	17
3.1 Control Signal	17
3.1.1 Control Input Connector Pin Arrangement	18
3.1.2 Control Output Connector Pin Arrangement	21
3.2 Control Timing and Signal Levels	23
3.3 Internal Register	25
3.4 Control Method	26
3.4.1 When Connected to a 3153 AUTOMATIC INSULATION/WITHSTANDING HiTESTER	26
3.4.2 When Connected to a Device Other Than the 3153 AUTOMATIC INSULATION/WITHSTANDING HiTESTER	27
Chapter 4 Specifications	29
Chapter 5 Maintenance and Service	31
5.1 Maintenance and Inspection	31
5.2 Cleaning	32

Introduction

Thank you for purchasing the HIOKI 3930 HIGH VOLTAGE SCANNER. To obtain maximum performance from the product, please read this manual first, and keep it handy for future reference.

Inspection

When you receive the product, inspect it carefully to ensure that no damage occurred during shipping. In particular, check the connectors and accessories. If damage is evident, or if it fails to operate according to the specifications, contact your dealer or Hioki representative.

Accessories

Control input connector connection cable (50-50 pin)	1
9615-01 H.V.TEST LEAD (HIGH side)	8
9615-02 H.V.TEST LEAD (LOW side)	1
Grounding cable	1
Instruction Manual	1

Before using the product the first time, verify that it operates normally to ensure that no damage occurred during storage or shipping. If you find any damage, contact your dealer or Hioki representative.



Before using the product, make sure that the insulation on the test leads is undamaged and that no bare conductors are improperly exposed. Using the product in such conditions could cause an electric shock, so contact your dealer or Hioki representative for repair.

Shipment of the unit

Use the original packing materials when reshipping the product, if possible.

Warranty

HIOKI cannot be responsible for losses caused either directly or indirectly by the use of the 3930 with other equipment, or if ownership is transferred to a third party.

Safety Notes



This product is designed to conform to IEC 61010 Safety Standards, and has been thoroughly tested for safety prior to shipment. However, mishandling during use could result in injury or death, as well as damage to the product. Be certain that you understand the instructions and precautions in the manual before use. We disclaim any responsibility for accidents or injuries not resulting directly from product defects.

This manual contains information and warnings essential for safe operation of the product and for maintaining it in safe operating condition. Before using the product, be sure to carefully read the following safety notes.

Safety Symbols

	<ul style="list-style-type: none"> The symbol printed on the product indicates that the user should refer to a corresponding topic in the manual (marked with the symbol) before using the relevant function. In the manual, the symbol indicates particularly important information that the user should read before using the product.
	Indicates that dangerous voltage may be present at this terminal.
	Indicates a fuse.
	Indicates AC (Alternating Current).
	Indicates a protective conductor terminal.
	Indicates the ON side of the power switch.
	Indicates the OFF side of the power switch.

The following symbols in this manual indicate the relative importance of cautions and warnings.

	Indicates that incorrect operation presents an extreme hazard that could result in serious injury or death to the user.
	Indicates that incorrect operation presents a significant hazard that could result in serious injury or death to the user.
	Indicates that incorrect operation presents a possibility of injury to the user or damage to the product.
	Advisory items related to performance or correct operation of the product.

Measurement categories

To ensure safe operation of measurement products, IEC 61010 establishes safety standards for various electrical environments, categorized as CAT II to CAT IV, and called measurement categories.

CAT II	Primary electrical circuits in equipment connected to an AC electrical outlet by a power cord (portable tools, household appliances, etc.) CAT II covers directly measuring electrical outlet receptacles.
CAT III	Primary electrical circuits of heavy equipment (fixed installations) connected directly to the distribution panel, and feeders from the distribution panel to outlets.
CAT IV	The circuit from the service drop to the service entrance, and to the power meter and primary overcurrent protection device (distribution panel).

Using a measurement product in an environment designated with a higher-numbered category than that for which the product is rated could result in a severe accident, and must be carefully avoided.

Use of a measurement instrument that is not CAT-rated in CAT II to CAT IV measurement applications could result in a severe accident, and must be carefully avoided.

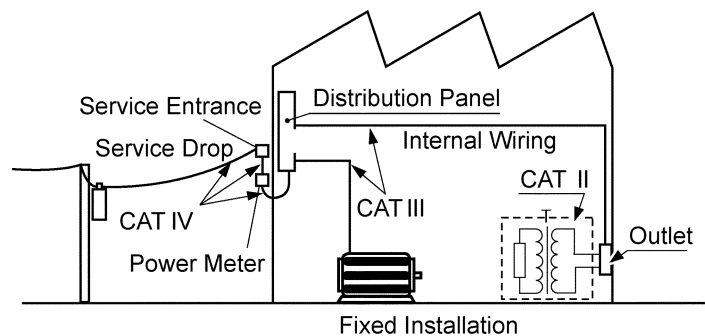

Notes on Use



Follow these precautions to ensure safe operation and to obtain the full benefits of the various functions.



-
- **To avoid electric shock, do not remove the product's case. The internal components of the product carry high voltages and may become very hot during operation.**
 - **The vinyl shield on the 9615-01 H.V. TEST LEAD alligator clip is not high voltage insulated. Do not touch when high voltage is applied.**
-



-
- **To avoid electric shock, do not allow the product to get wet, and do not use it when your hands are wet.**
 - **To avoid electric shock, be sure to connect the protective conductor to earth (earth ground).**
 - **Before turning the product on, make sure the supply voltage matches that indicated on its power connector. Connection to an improper supply voltage may damage the product and present an electrical hazard.**
 - **To avoid electric shock, when directly touching the high voltage test leads or a device to be tested, wear rubber-insulated gloves and make sure that the automatic control is stopped.**
-



-
- To avoid damaging the power cord, grasp the plug, not the cord, when unplugging the cord from the power outlet.
 - To avoid damaging the 9615-01, 9615-02 H.V. TEST LEAD, do not kink or pull on the leads.
 - For safety reasons, when taking measurements, only use the 9615-01, 9615-02 H.V. TEST LEAD provided with the product.
 - To avoid damage to the product, protect it from vibration or shock during transport and handling, and be especially careful to avoid dropping.
-



-
- Do not use the product near a device that generates a strong electromagnetic field or electrostatic charge, as these may cause erroneous measurements.
 - This product may cause interference if used in residential areas. Such use must be avoided unless the user takes special measures to reduce electromagnetic emissions to prevent interference to the reception of radio and television broadcasts.
-

Chapter Summary

Chapter 1 Overview

Describes an overview, features, and the names and functions of the parts of the product.

Chapter 2 Testing Arrangements

Describes particulars of testing arrangements.

Chapter 3 Control Signal and Control Method

Describes the control signal and control method when using a device other than the 3153 as the master unit.

Chapter 4 Specifications

Contains the unit specifications such as the general specifications, measurement accuracy, etc. of the unit.

Chapter 5 Maintenance and Inspection

Covers the maintenance, inspection and ultimate disposal.

Chapter 1 Overview

1.1 Product Introduction

The 3930 is a passive auxiliary tester that is connected to and controlled by a master unit (the 3153 AUTOMATIC INSULATION/WITHSTANDING HiTESTER, or a sequencer). The 3930 cannot operate on a standalone basis.

This auxiliary tester is designed to safely permit testing of multiple locations with a minimum of connection changes. This unit can output from any channel high voltage that is input through a high-voltage input cord simply by turning the internal high-voltage relays on and off. Up to four of these units can be connected to a single master unit, with each unit identified by a unique ID.

1.2 Features



In order to prevent electric shock, use voltage to ground that is at or less than the SELV* on the LOW side of the high-voltage input cords. Although the LOW side of the high-voltage input cords is functionally insulated from ground, there is no withstand voltage.

*: SELV (separated external low voltage): effective value of 30 V, peak value of 42.4 V

(1) Direct connection to the 3153

The 3930 can be directly connected to the 3153 AUTOMATIC INSULATION/WITHSTANDING HiTESTER. Because the 3153 supplies power to the 3930, no separate power supply is needed.

(2) Single mode and Multi-mode

The 3930 has two operation modes: single mode and multi-mode. Single mode permits testing of eight channels using the one COM channel and eight high-output channels. Multi-mode permits testing of four pairs of two different high-output channels.

(3) Multiple channels

In single mode, the 3930 can test eight channels. In multi-mode, the 3930 can test four channel pairs. In addition, a unique ID can be set for each unit, allowing a maximum of four 3930s to be connected to a single master unit.

(4) Output channel indicators

The LEDs on the front panel indicate the current mode and the channels that are being output.

(5) Insulated design

The power supply, the high-voltage inputs and outputs, and the control input connector signal wires are all functionally insulated.

(6) Signal level from 5 to 24 V

Devices ranging from general logic to a sequencer can be connected by selecting the supply voltage for the control signal system.

(7) Safe design that avoids duplicate IDs

When multiple 3930s are connected, the unit can detect incorrect (duplicate) ID settings. When a mistake is detected, all output is shut off.

1.3 Names and Functions of Parts

1.3.1 Front panel



In order to avoid electric shock, never touch the high-voltage output terminals (high, low), high-voltage test leads or the device being tested while high voltage is being applied.

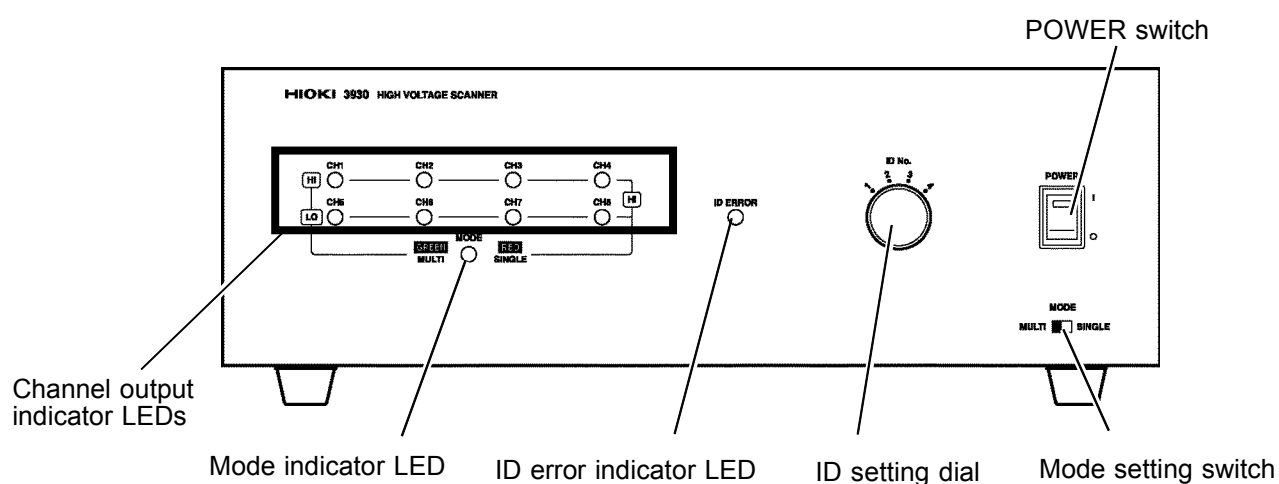

Channel output indicator LEDs	These LEDs light when the relay for the corresponding channel is on. (Red: voltage output; green: COM connected)
Mode indicator LED	Indicates the mode that is set by the mode setting switch. (Red: single mode; green: multi-mode)
ID error indicator LED	Lights red if a duplicate ID is detected when multiple 3930s are connected.
ID setting dial	Sets the ID of this 3930.
Mode setting switch	Sets the mode of this 3930 (single mode or multi-mode).
POWER switch	Turns on the 3930.

1.3.2 Rear panel



In order to avoid electric shock, never touch the high-voltage output terminals (high, low), high-voltage test leads or the device being tested while high voltage is being applied.

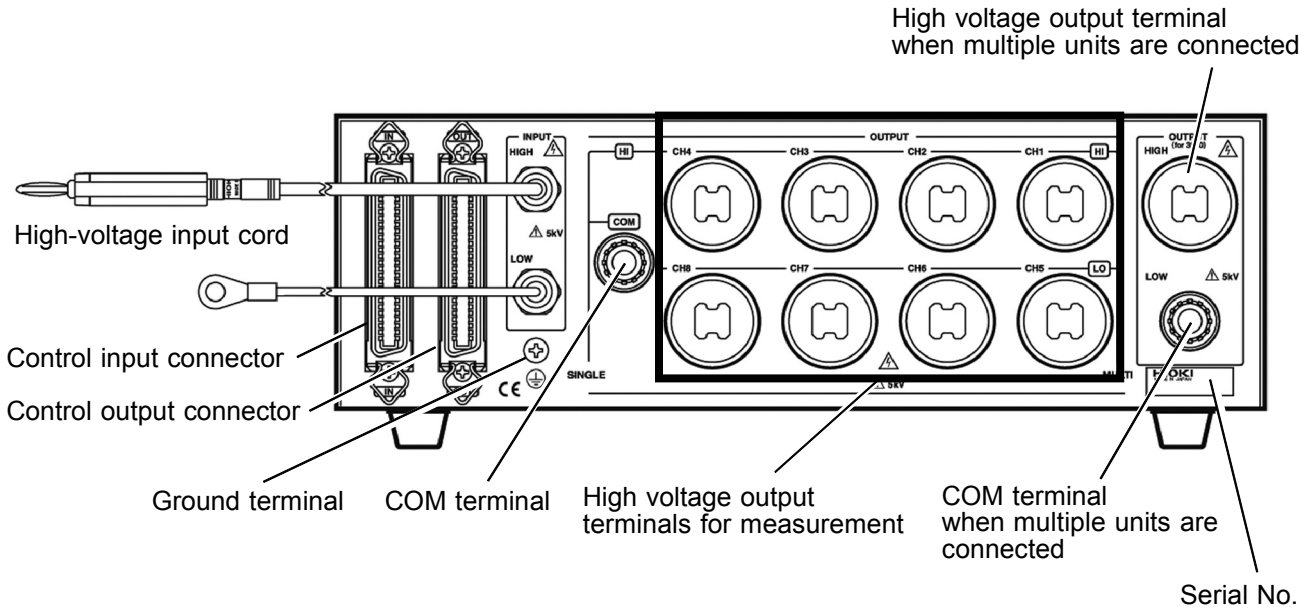

High-voltage input cord	This cord is used to input high voltage. Use voltage to ground that is at or less than the SELV* on the LOW side.
Control input connector	This connector is used to control the 3930.
Control output connector	This connector is used to connect multiple 3930s.
Ground terminal	This terminal grounds the 3930 case.
COM terminal	This terminal is connected to the LOW side of the high-voltage input cord. In single mode, this terminal is the LOW side common input.
High voltage output terminals for measurement	These are the output terminals that are connected to the device being measured.
COM terminal when multiple units are connected	This is the LOW side output terminal when multiple 3930s are connected.
High voltage output terminal when multiple units are connected	This is the high-voltage output terminal when multiple 3930s are connected.
Serial No.	This is the high-voltage output terminal when multiple 3930s are connected. The serial number consists of 9 digits. The first two (from the left) indicate the year of manufacture, and the next two indicate the month of manufacture. Required for production control. Do not peel off the label.

*: SELV (separated external low voltage): effective value of 30 V, peak value of 42.4 V

1.3.3 9615-01, 9615-02 H.V. TEST LEAD (Accessories)



The vinyl sheath on the alligator clip of the 9615-01 and 9615-02 H.V. TEST LEAD does not have an insulation withstand voltage. In order to avoid electric shock, never touch the alligator clip while high voltage is being generated.

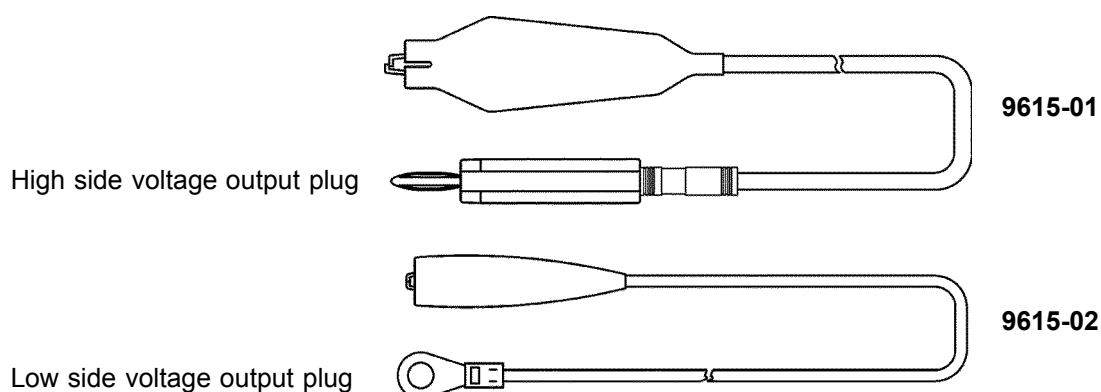

Alligator clip	Attach to the test point on the device being measured.
High side voltage output plug	Connect to a high-voltage output terminal for measurement on the 3930.
Low side voltage output plug	Connect to the COM terminal on the 3930.

NOTE

When used in a humid environment, it is possible that the H.V. TEST LEAD could attract moisture, creating an increase in leak current. Under these conditions, we recommend applying conformal coatings to the 9615-01 or 9615-02, except for the metallic connector surfaces.

Recommended conformal coatings: HumiSeal 1A27NSLU (AR BROWN)

If a 9615-01 or 9615-02 H.V. TEST LEAD will be in contact with or in the vicinity of a metal surface while it is used, or if it must be used in a bundled state, take measures such as wrapping the lead wire with a spiral tube that will maintain a separation of 5 to 10 mm between lead wires or between the lead wire and the metal surface. This will prevent capacitive coupling between the lead wire and the metal surface or between lead wires, an increase of leak current, or the radiation of noise.

1.4 External Dimensions

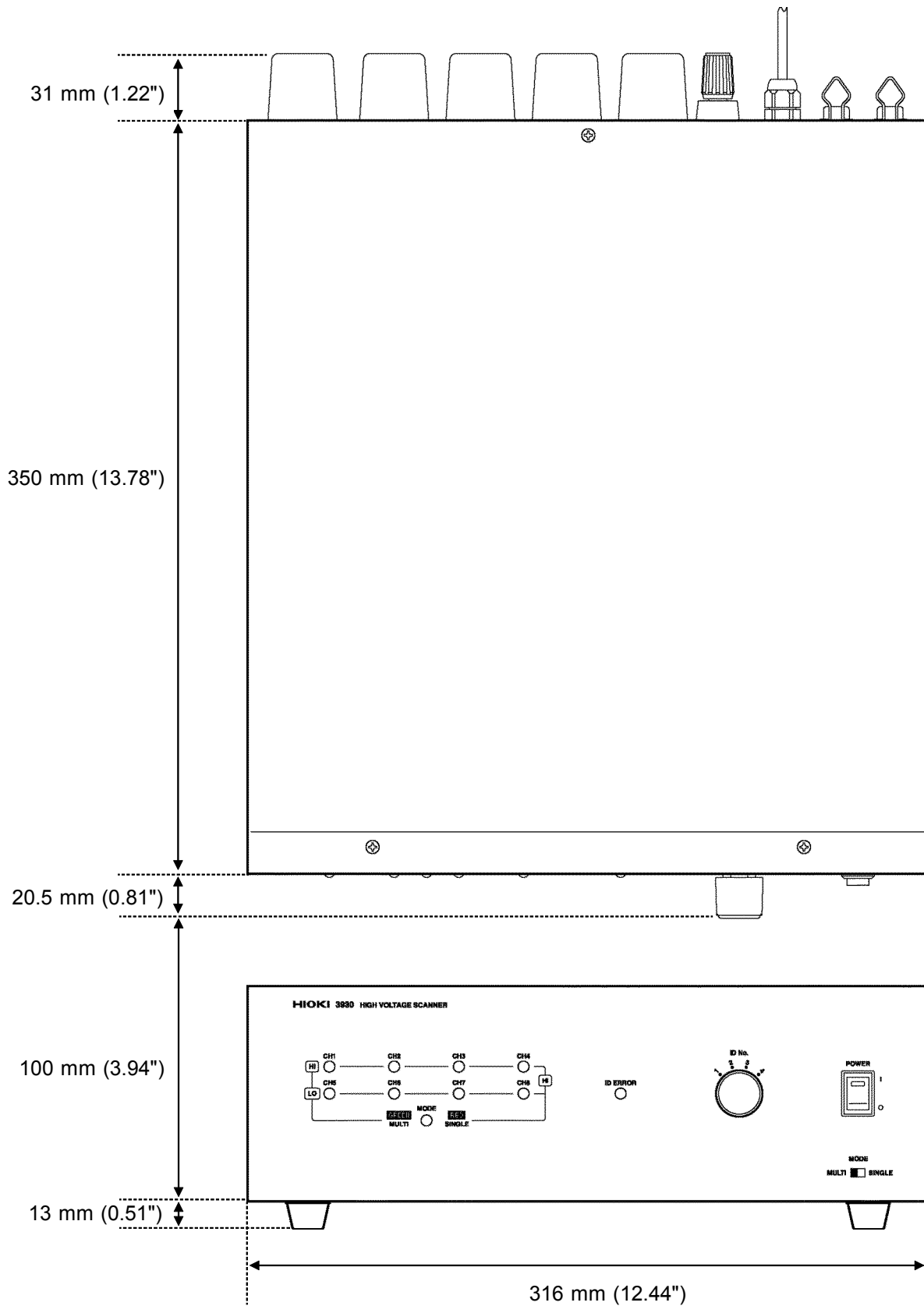

Chapter 2

Testing Arrangements

2.1 Terms

This section explains several terms that should be understood before using this device.

(1) Master unit

The 3930 is a passive auxiliary tester that is connected to and controlled by a master unit (the 3153 AUTOMATIC INSULATION/WITHSTANDING HiTESTER, or a sequencer). The 3930 cannot operate on a standalone basis.

In this manual, the term "master unit" is applied to devices that control the 3930 (such as the 3153 AUTOMATIC INSULATION/WITHSTANDING HiTESTER or a sequencer) and to devices that supply high voltage or high current and high voltage.

(2) IDs and distance from the master unit

Up to four 3930s can be connected to and independently controlled by one master unit. In order to permit this, the unit has four scanner control signals (inputs), and an ID can be set in order to select which scanner control signal to use. The ID is represented by a number from "1" to "4," and is set by means of the ID setting dial.

When connecting multiple units, only one unit can be connected directly to the master unit; the other three are connected in daisy chain fashion to the first 3930. In this manual, references to the distance between a specific 3930 and the master unit are based on the number of 3930s between the unit and the master unit, not the physical distance of the unit to the master unit or the relative value of the unit's ID number.

(3) ID error



In order to avoid electric shock, a short circuit or damage to the equipment, do not change the ID while the power is on for the 3930 or the master unit, or while voltage is being applied.

This unit cannot be controlled correctly if the scanner control signal number and the ID number do not match. In addition, in order to ensure safety, if there is more than one 3930 with the same ID number connected to a single master unit, an ID error is indicated on the 3930 with the duplicate ID number. The ID error indicator LED lights, all output relays turn off in the 3930 with the duplicate ID, and that unit can not be controlled by the master unit.

In this event, stop testing, turn off the power for the master unit and the main unit, and set the IDs correctly.



When multiple 3930s are connected, note that when duplicate IDs exist, no ID error is detected in the 3930 that is connected in the position that is farthest from the master unit.

(4) Single mode



In order to avoid electric shock, a short circuit or damage to the equipment, do not change the ID while the power is on for the 3930 or the master unit, or while voltage is being applied.

In this mode, the 3930 tests eight high-voltage output channels paired with the COM channel.

The devices being tested are connected between the high voltage output terminal for each channel and the COM terminal. When this mode is set, the mode indicator LED lights red, indicating single mode. All terminals for CH1 to 8 on the 3930 are high-voltage output terminals. The voltage that is input through the high-voltage input cord is output from the channels for which the corresponding relays are on, and the output indicator LED lights red.



When multiple 3930s are connected to one 3153, set all 3930s to the same mode. If 3930s set to different modes are connected to one 3153, a connection error will be generated.

(5) Multi-mode



In order to avoid electric shock, a short circuit or damage to the equipment, do not change the ID while the power is on for the 3930 or the master unit, or while voltage is being applied.

In this mode, the 3930 tests four pairs of two different high-voltage output channels. CH1 to 4 are connected to the high-voltage output (HIGH side), and CH5 to 8 are connected to COM (LOW side). The device being tested is connected between the two corresponding channels. If this mode is set, the mode indicator LED lights green, indicating multi-mode. When the 3930 is connected to the 3153, it is possible to measure between multiple pairs of different points by combining any one of CH1 to 4 and any one of CH5 to 8. The LEDs for the two channels that are being measured light, indicating that measurement is occurring between those channels. The LEDs for the high-voltage outputs (CH1 to 4) light red, and the LEDs for the COM terminal (CH5 to 8) light green.



When multiple 3930s are connected to one 3153, set all 3930s to the same mode. If 3930s set to different modes are connected to one 3153, a connection error will be generated.

(6) Mode error

When MD1 of the status information (refer to chapter 3, "Control Signals and Control Methods") is low, it indicates the existence of an abnormality in an internal circuit, such as a slide switch, which means that the mode is not set correctly.

When a mode error is detected, stop using the unit and contact your nearest dealer or our sales office.



If a mode error is detected, the output relay is controlled but the voltage that is input from the high-voltage input cord is not output on the high-voltage output pin.

2.2 Installation of the Unit

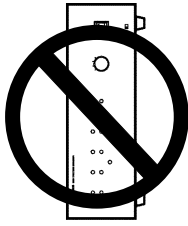

Temperature: 0 to 40°C

Humidity: 80% RH or less (no condensation)

Do not install the instrument upside-down, or stand it on its side.

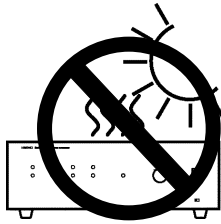

Avoid the following locations:

- Subject to direct sunlight.



- Subject to high levels of dust, steam, or corrosive gases (Avoid using the equipment in an environment containing corrosive gases (e.g., H₂S, SO₂, NI₂, and Cl₂) or substances that generate harmful gasses (e.g., organic silicones, cyanides, and formalins)).

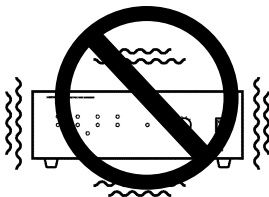

- Subject to vibrations.
- In the vicinity of equipment generating strong electromagnetic fields.



The noise generated by this unit may affect equipment located around the unit.

2.3 Connection

2.3.1 Connecting the Protective Conductor Terminal



-
- To avoid electric shock, connect the protective conductor terminal to earth (earth ground) before making any other connections.
 - To avoid electric shock, be sure to connect the protective conductor to earth (earth ground).
-

1. Using a Phillips-head screwdriver, remove the protective conductor terminal from the rear of the unit.
2. Connect a specified grounding cable or an electric wire with a sufficient current capacity to the protective conductor terminal, and secure the wire using a Phillips-head screwdriver.
3. Ground the other end of the wire.

3930 rear panel

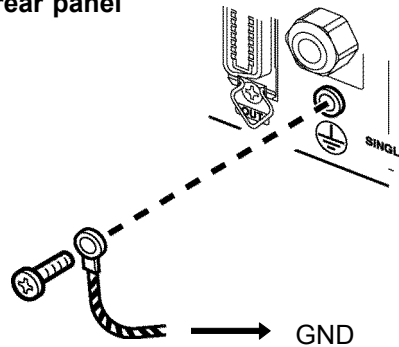

2.3.2 Setting the Mode



In order to avoid electric shock or damage to the equipment, do not change the mode while the power is on for the 3930 or the master unit, or while voltage is being applied to the high-voltage input cord.

The 3930 can be set to either single mode or multi-mode. Use tweezers or a flat-head screwdriver to change the mode. For details on the modes, refer to section 2.1, "Terms."

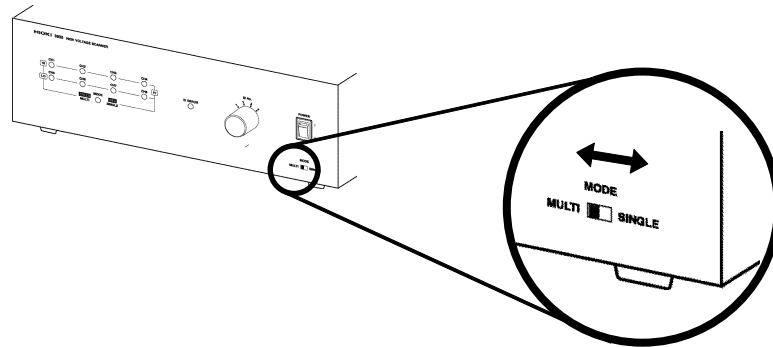

2.3.3 Setting the ID



In order to avoid electric shock or damage to the equipment, do not change the ID while the power is on for the 3930 or the master unit, or while voltage is being applied to the high-voltage input cord.

Turn the ID setting dial on the 3930 to set the ID. When multiple 3930s are connected, set a unique ID for each unit. If two of the units have duplicate IDs, the ID error indicator LED lights on the unit with the duplicate ID, all output relays turn off, and that unit stops accepting control input.

Be sure that the ID correctly corresponds with the connection status of the 3930.

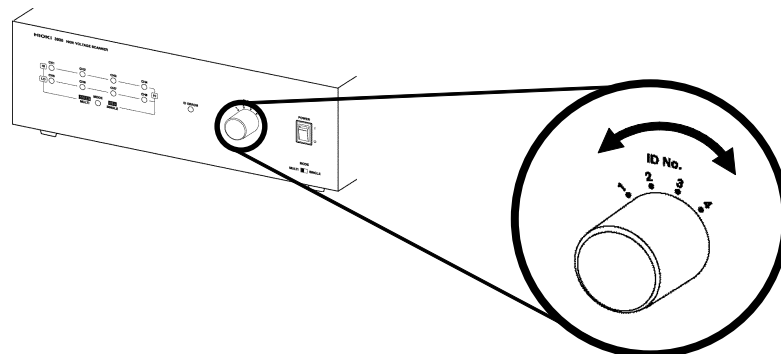

2.3.4 Control Connector Connection



In order to avoid electric shock or damage to the equipment, do not connect or disconnect the control connectors while the power is on for the 3930 or the master unit, or while voltage is being applied to the high-voltage input cord.

1. Confirm that the power is off for the master unit and for the 3930.
2. Connect the 3930's control input connector to the master unit.
When using the 3153 AUTOMATIC INSULATION/WITHSTANDING HiTESTER as the master unit, use the control input connector cable provided to make the connection.

3930 rear panel

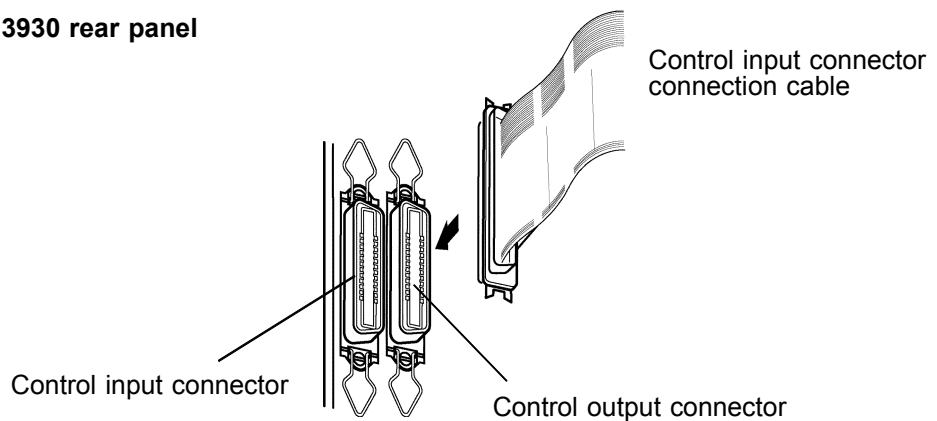

When connecting multiple 3930s, connect the control input connector to the control output on the preceding 3930.

When using a device other than the 3153 AUTOMATIC INSULATION/WITHSTANDING HiTESTER as the master unit, refer to Chapter 3, "Control Signals and Control Methods," and be sure to make all connections correctly.

Do not connect any device other than another 3930 to the control output connector.

2.3.5 High-voltage Input Cord and H.V. TEST LEAD Connection

1. Confirm that the high-voltage output from the master unit is off.
2. Connect the high-voltage input cord to the high-voltage output terminal on the master unit.
3. Using the H.V. TEST LEAD provided, connect the 3930 to the test portion of the device to be tested.

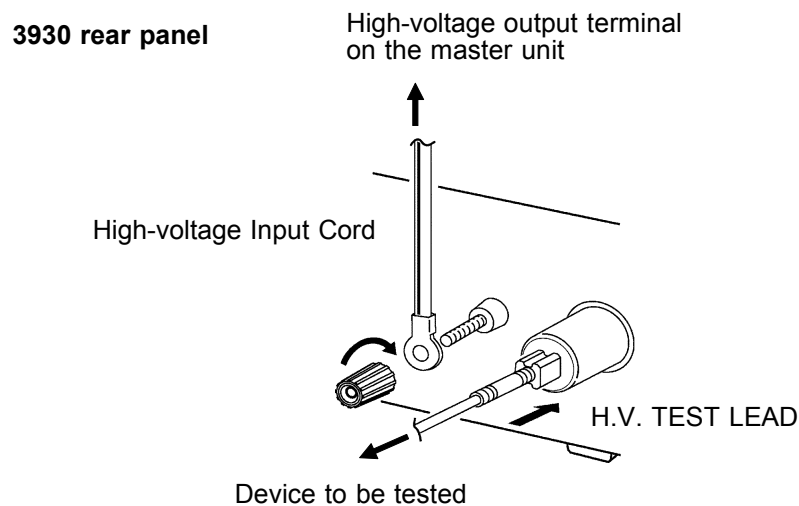

NOTE

The leak current will be increased by contacting the high-voltage input cord and the H.V. TEST LEAD with a metal face directly, or using the High and the Low side voltage cord in a bundled state.

Taking measures is recommended, such as wrapping the lead wire with a spiral tube that will maintain a separation of 5 to 10 mm between one lead wire and another, or between the lead wires and the metal surface.

This will prevent an increase of the leak current, or a radiation of noise, resulting from a capacitive coupling between one lead wire and another, or between the lead wires and the metal surface.

2.3.6 Powering On and Off the Unit

⚠ CAUTION

Always observe the following cautions in order to avoid damaging the equipment:

- Before turning on the power, confirm that there is no voltage being applied to the high-voltage input cord.
- Carefully read Chapter 3, "Control Signals and Control Methods," check the supply voltage and the connections, and then turn on the power.
- Turn on the master unit first, before turning on the 3930.

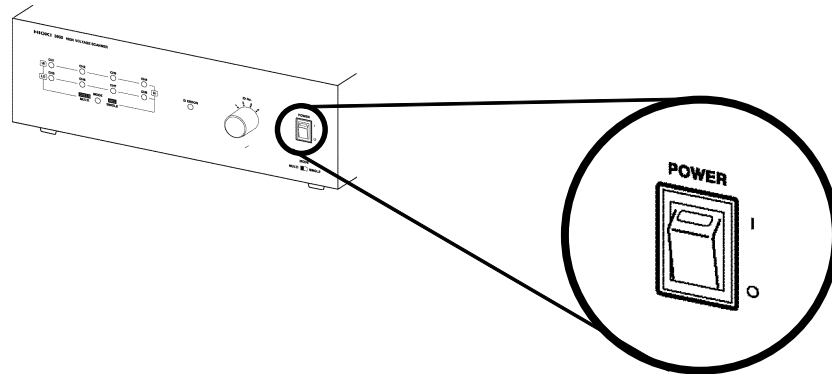

Turning on the power

After first confirming that the master unit has already been turned on and that no voltage is being applied to the high-voltage input cord, turn the POWER switch ON (I).

Turning off the power

After first confirming that no voltage is being applied to the high-voltage input cord, turn the POWER switch OFF (O).

This unit requires two power supplies: 24V DC between power supply SCV and SCG to drive the relays and to control the internal circuitry, and 5 to 24V between power supply ISO_V and ISO_G to drive the photocouplers for isolation (for determining the input signal level). Although SCG, ISO-G and the LOW side of the high-voltage input cord are insulated from each other, they are not insulated when the 3153 AUTOMATIC INSULATION/WITHSTANDING HiTESTER is being used as the master unit. Regarding ISO_V, carefully read Chapter 3, "Control Signals and Control Methods," and then select ISO_V according to the master unit being used to control the 3930.

NOTE

When using a sequencer, for example, and the control signal level is 24 V and no insulation is required, SCV and ISO_V can be used in common. Carefully read Chapter 4, "Specifications," and then keep the current capacities in mind while connecting SCV to ISO_V, and SCG to ISO_G.

2.4 Startup Inspection



In order to avoid electric shock, allow at least 6ms to elapse after turning on a relay before applying voltage to the high-voltage input cord.

The relays used in the 3930 require approximately 6 ms for the contact to completely close or open. When stopping a test, cut off the voltage and allow the test terminal voltage to reach the SELV* before turning a relay off. If a relay is turned on or off while high-voltage current is flowing through it, deposits may form on the relay, ultimately allowing voltage to be output from an unexpected source.

*: SELV (separated external low voltage): effective value of 30 V, peak value of 42.4 V

In order to ensure safe operation, an initial inspection should be performed according to the procedure described below.

1. Create a program ("Program 1") that turns on each channel in sequence in single mode.
2. Create a program ("Program 2") that turns on each channel in sequence in multi-mode.
3. After confirming that the power is off for both the 3930 and the master unit, connect the control input connector to the master unit. Do NOT connect the high-voltage input cord.
4. Set the 3930 to single mode, and then turn on the master unit and the 3930. After confirming that the mode indicator LED is red, confirm that there is no continuity between the HIGH and LOW sides of the high-voltage input cord.
5. Execute Program 1, and confirm the following:
 - Confirm that there is continuity between the HIGH side of the high-voltage input cord and the high-voltage output terminals of the channels for which the LEDs are lit.
 - Confirm that there is no continuity between the HIGH side of the high-voltage input cord and the high-voltage output terminals of the channels for which the LEDs are not lit.
6. Turn off the 3930 and the master unit, set the 3930 to multi-mode, and then turn both units back on again. Do NOT connect the high-voltage input cord.
7. After confirming that the mode indicator LED is green, confirm that there is no continuity between the HIGH and LOW sides of the high-voltage input cord.
8. Execute Program 2, and confirm the following:
 - Confirm that there is continuity between each of the channels for which the CH5 to 8 LED is lit (green) and the low side of the high-voltage input cord.
 - Confirm that there is no continuity between each of the channels for which the CH5 to 8 LED is not lit and the low side of the high-voltage input cord.

If an abnormality is discovered during the initial inspection, stop using the unit and contact your nearest dealer or our sales office.

Chapter 3

Control Signal and Control Method

3.1 Control Signal

This section describes the control signal and control timing requirements when using a device other than the 3153 AUTOMATIC INSULATION/WITHSTANDING HiTESTER as the master unit.

NOTE

The 3930's power supply inputs (SCV and SCG), the photocoupler drive power supplies (ISO_V and ISO_COM), and the high-voltage input cord (HIGH side and LOW side) are all insulated from each other. When using the 3153, note that these lines are not insulated from each other within the 3153.

3.1.1 Control Input Connector Pin Arrangement

This section describes the signals in the control input connector (rear panel).

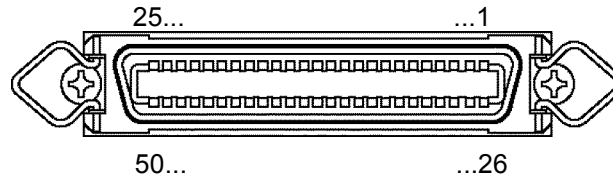

Pin No.	Signal	I/O	Function	Pin No.	Signal	I/O	Function
1	SCAN4	I	Scanner control signals These signals are used to select the 3930 that is to be controlled.	26	ID1E	O	These indicate that ID1 exists.
2	SCAN3	I		27	ID1O	O	
3	SCAN2	I		28	ID2E	O	These indicate that ID2 exists.
4	SCAN1	I		29	ID2O	O	
5	A2	I	Address signals These signals select a register within the 3930. For details on how to control these signals correctly, refer to "Control timing and signal levels" and "Internal registers."	30	ID3E	O	These indicate that ID3 exists.
6	A1	I		31	ID3O	O	
7	A0	I		32	ID4E	O	These indicate that ID4 exists.
8	D7	I	Data signals These signals turn relays on and off. For details on how to control these signals correctly, refer to "Control timing and signal levels."	33	ID4O	O	
9	D6	I		34	MD4	O	Mode signals These indicate the status of the 3930s that are connected.
10	D5	I		35	MD3	O	
11	D4	I		36	MD2	O	
12	D3	I		37	MD1	O	
13	D2	I		38	N.C.	—	No connection Do not connect any lines to these pins.
14	D1	I	39	—			
15	D0	I	40	—			
16	ISO_V		Isolation power supply This power supply drives the photocouplers for internal isolation. Input 5 to 24 V (DC) between these pins and ISO_COM. Refer to "Control timing and signal levels" and then select the voltage appropriate for the master unit being used. These pins are connected to ISO_V in the control output connector.	41	ISO_COM		Isolation power supply This power supply drives the photocouplers for internal isolation. (LOW side) Input 5 to 24 V (DC) between these pins and ISO_V. These pins are connected to ISO_COM in the control output connector.
17				42			
18	SCV		Scanner power supply These are 24V DC (HIGH side) inputs. Input 24V DC between these pins and SCG. These pins are connected to SCV in the control output connector.	43	SCG		Scanner power supply These are 24V DC (LOW side) inputs. Input 24V DC between these pins and SCG. SCG is connected to the case ground. These pins are connected to SCV in the control output connector.
19				44			
20				45			
21				46			
22				47			
23				48			
24				49			
25				50			

Scanner control signal ($\overline{\text{SCANx}}$) inputs

These signals control the scanner. The scanner control signal that has the same ID number as the unit is used. The data signals are fetched and the relays are turned on/off at the rising edge of this signal. When this signal is low, valid internal status signals are output. For details on how to control these signals correctly, refer to "Control timing and signal levels."

Address signal (A2 to A0) inputs

These address lines are used to select the 3930's internal registers. For details on how to control these signals correctly, refer to "Control timing and signal levels" and "Internal registers."

Data signal (D7 to D0) inputs

These data signals are used to control the internal relays. If any of these signals are high at the rising edge of the scanner control signal, the corresponding relays turn on. If any of these signals are low at the rising edge of the scanner control signal, the corresponding relays turn off. For details on how to control these signals correctly, refer to "Control timing and signal levels."

Isolation power supply (ISO_V) inputs

This power supply drives the photocouplers for internal isolation. Input 5 to 24 V (DC) between these pins and ISO_COM. Refer to "Control timing and signal levels" and then select the voltage appropriate for the master unit being used.

Scanner power supply (SCV) inputs

These are 24V DC (HIGH side) inputs. Input 24V DC between these pins and SCG.

ID check signal 1 ($\overline{\text{IDxE}}$) output

When this signal is low, it indicates that IDx exists.

ID check signal 2 ($\overline{\text{IDxO}}$) output

When this signal is low, it indicates that IDx is duplicated.

Mode signal (MD4 to MD1) outputs

These signals output 3930 status information. For details on each signal, refer to "Internal registers."

No connection (N.C.)

Do not connect any lines to these pins.

Isolation power supply (ISO_COM) inputs

This power supply drives the photocouplers for internal isolation (LOW side). Input 5 to 24 V (DC) between these pins and ISO_V.

Scanner power supply (SCG) inputs

These are 24V DC (LOW side) inputs. Input 24V DC between these pins and SCG. SCG is connected to the case GND.

NOTE

The 3930's power supply inputs (SCV and SCG), the photocoupler drive power supplies (ISO_V and ISO_COM), and the high-voltage input cord (HIGH side and LOW side) are all insulated from each other. When using the 3153, note that these lines are not insulated from each other within the 3153.

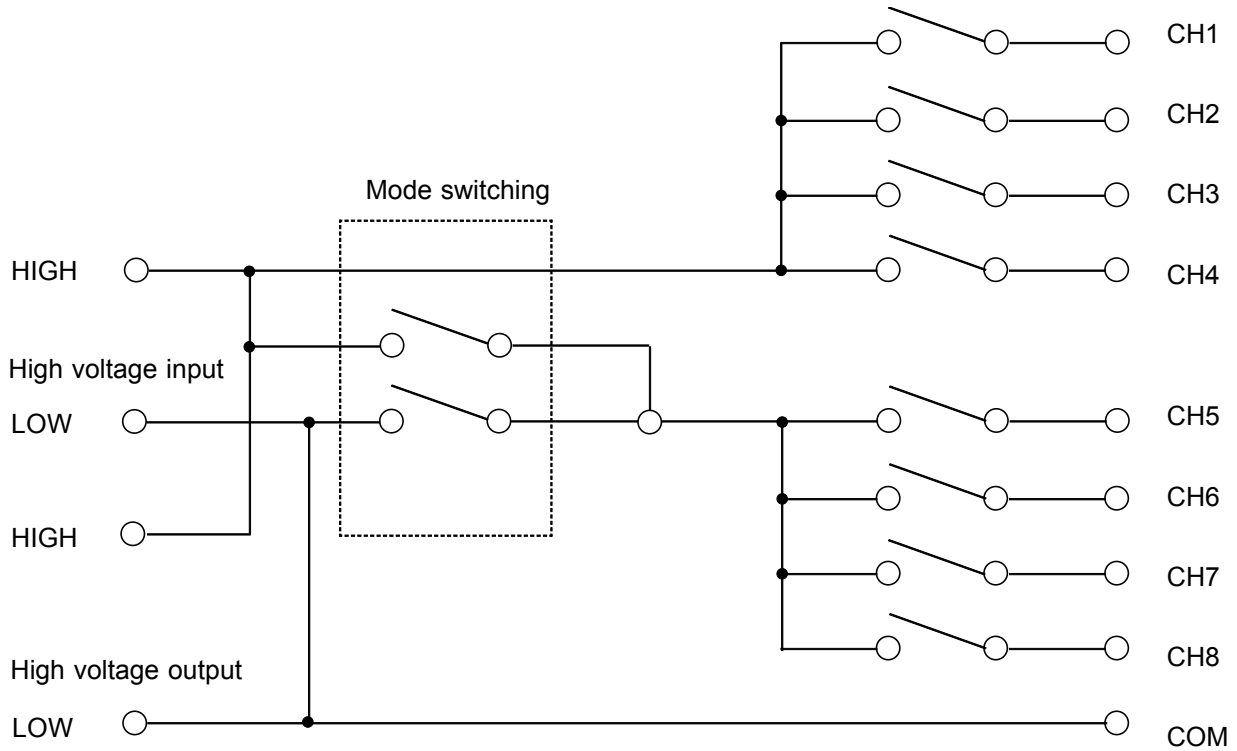

Basic Connection Figure

Control Input Connector Output signals

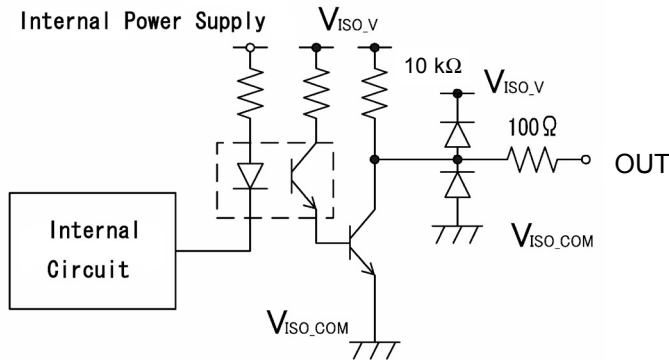

Control Input Connector Input signals

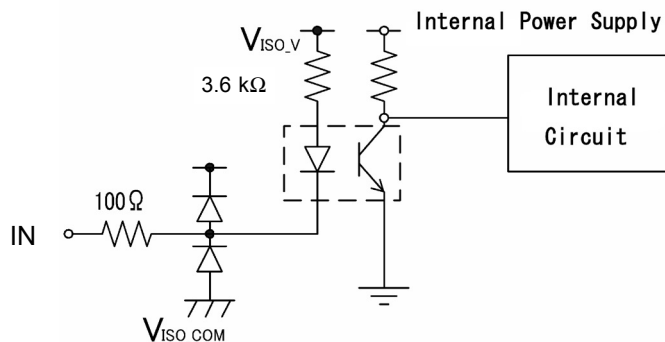

3.1.2 Control Output Connector Pin Arrangement

This section describes the signals in the control output connector (rear panel).

Do not connect any device other than another 3930 HIGH VOLTAGE SCANNER to the control output connector. The following table is provided for informational purposes.

Pin No.	Signal	I/O	Function	Pin No.	Signal	I/O	Function
1	$\overline{\text{SCAN4}}$	O	Scanner control signals These signals are used to select the 3930 that is to be controlled.	26	$\overline{\text{ID1E}}$	I	ID check signal 1 input This is the scanner connection information from the preceding 3930. This is isolated by a photocoupler.
2	$\overline{\text{SCAN3}}$	O		27	$\overline{\text{ID1O}}$	I	ID check signal 2 input This is the scanner connection information from the preceding 3930. This is isolated by a photocoupler.
3	$\overline{\text{SCAN2}}$	O		28	$\overline{\text{ID2E}}$	I	Information from the preceding 3930 is input.
4	$\overline{\text{SCAN1}}$	O		29	$\overline{\text{ID2O}}$	I	
5	A2	O	30	$\overline{\text{ID3E}}$	I		
6	A1	O	Address signals These are address signals used to select a register within the 3930. These address signals are used to control the 3930 that is connected to this connector.	31	$\overline{\text{ID3O}}$	I	
7	A0	O		32	$\overline{\text{ID4E}}$	I	
8	D7	O		33	$\overline{\text{ID4O}}$	I	
9	D6	O	Data signals These data signals are used to control the internal relays in the 3930 that is connected to this connector. The D7 to D0 signals that are input through the control input connector are output through these signals as is.	34	MD4	I	Mode signal inputs These signals are the bus for inputting 3930 status information. For details on each signal, refer to "Internal registers."
10	D5	O		35	MD3	I	
11	D4	O		36	MD2	I	
12	D3	O		37	MD1	I	
13	D2	O		38	N.C.	—	No connection Do not connect any lines to these pins.
14	D1	O		39		—	
15	D0	O		40		—	

Pin No.	Signal	I/O	Function	Pin No.	Signal	I/O	Function																
16	ISO_V		Isolation power supply This power supply (HIGH side) drives the photocouplers for internal isolation in the 3930 that is connected to this connector. 5 to 24 V (DC) is output between these pins and ISO_COM. These pins are connected to ISO_V in the control input connector.	41	ISO_COM		Isolation power supply This power supply drives the photocouplers for internal isolation (LOW side) in the 3930 that is connected to this connector. 5 to 24 V (DC) is output between these pins and ISO_V. These pins are connected to ISO_COM in the control input connector.																
17				42				18	SCV		Scanner power supply This is a power supply (HIGH side) for the 3930 that is connected to this connector. 24V DC is output between these pins and SCG.	43	SCG		Scanner power supply This is a power supply (LOW side) for the 3930 that is connected to this connector. 24V DC is output between these pins and SCG. SCG is connected to the case ground.	19	44	20	45	21	46	22	47
18	SCV		Scanner power supply This is a power supply (HIGH side) for the 3930 that is connected to this connector. 24V DC is output between these pins and SCG.	43	SCG		Scanner power supply This is a power supply (LOW side) for the 3930 that is connected to this connector. 24V DC is output between these pins and SCG. SCG is connected to the case ground.																
19				44																			
20				45																			
21				46																			
22				47																			
23				48																			
24				49																			
25				50																			

3.2 Control Timing and Signal Levels

Control Timing

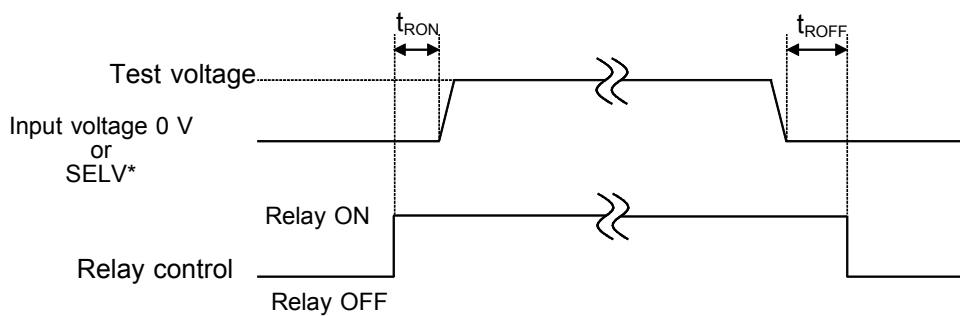
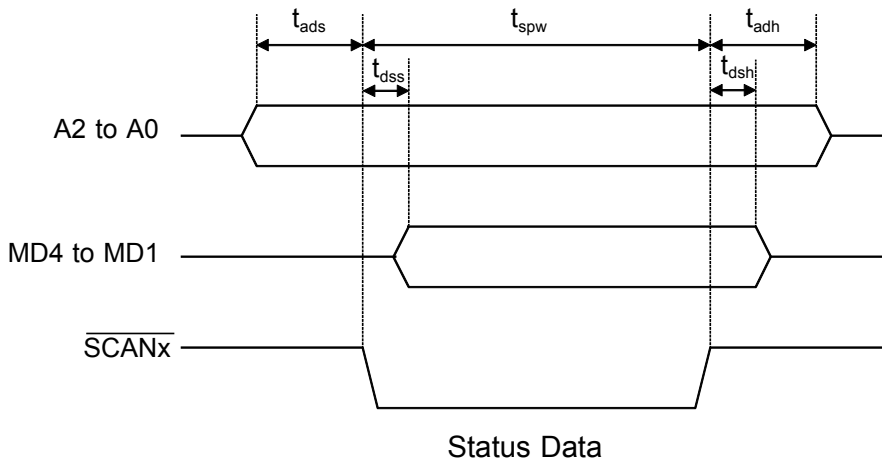
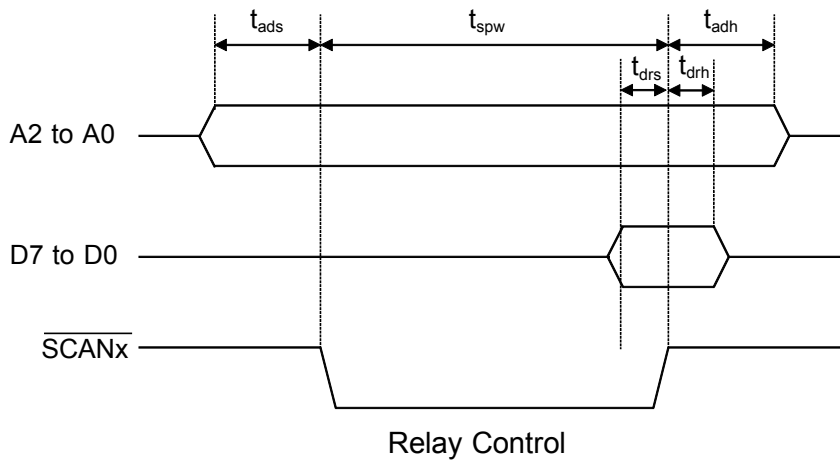
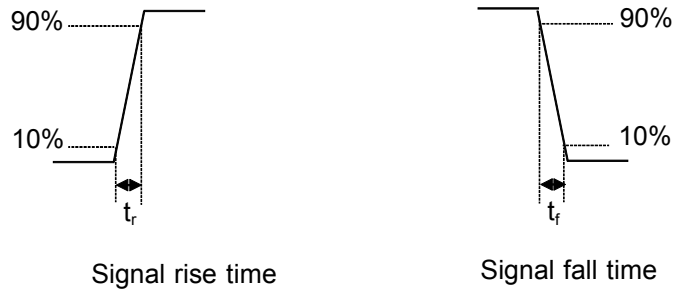

*: SELV (separated external low voltage): effective value of 30 V, peak value of 42.4 V

Test-voltage and Relay control

Timing table

Symbol	Period	MAX.	MIN.
t_r	Signal rise time	0.5 ms	—
t_f	Signal fall time	0.5 ms	—
t_{ads}	Address setup time before falling edge of \overline{SCANx}	—	0 ms
t_{spw}	\overline{SCANx} pulse width	—	5 ms
t_{adh}	Address hold time after rising edge of \overline{SCANx}	—	2 ms
t_{drs}	Data setup time until rising edge of \overline{SCANx}	—	0.5 ms
t_{drh}	Data hold time after rising edge of \overline{SCANx}	—	2 ms
t_{dss}	MD settling time after rising edge of \overline{SCANx}	—	2 ms
t_{dsh}	MD hold time after rising edge of \overline{SCANx}	—	0.5 ms
t_{ron}	Delay after relay on until test voltage output starts	—	6 ms
t_{roff}	Delay after high-voltage output is off until relay off	—	6 ms

Signal level

V_{ISO_V} : ISO_V terminal voltage

V_{ISO_COM} : ISO_COM terminal voltage

Input level (unit: V)

	Maximum	Minimum
HIGH level	$V_{ISO_V} + 1.0$	$V_{ISO_V} - 1.5$
LOW level	$V_{ISO_V} - 4.0$	$V_{ISO_COM} - 0.5$

Output level (unit: V)

	Maximum	Minimum
HIGH level	V_{ISO_V}	$V_{ISO_V} - 0.5$
LOW level	$V_{ISO_COM} + 0.5$	$V_{ISO_COM} - 0.5$

3.3 Internal Register

Normal control is not possible if one of the multiple 3930s that is connected detects an ID error.

R/W: R (read only), W (write only)

A2	A1	A0	R/W	Function
0	0	0	W	Relay control
0	0	1	—	Reserved (not used)
0	1	0	—	Reserved (not used)
0	1	1	—	Reserved (not used)
1	0	0	R	Status
1	0	1	—	Reserved (not used)
1	1	0	—	Reserved (not used)
1	1	1	—	Reserved (not used)

Relay Control Address

Address	R/W	D7	D6	D5	D4	D3	D2	D1	D0
\$0	W	CH8	CH7	CH6	CH5	CH4	CH3	CH2	CH1

The status of each signal line (D7 to D0) at the rising edge of the scanner control signal ($\overline{\text{SCAN}}_x$) is reflected in the relays.
(HIGH: relay on; LOW: relay off)

Status Reading Address

Address	R/W	MD4	MD3	MD2	MD1
\$4	R	—	$\overline{\text{S/M}}$	—	$\overline{\text{MDE}}$

Valid data is output on each signal line (MD4 to MD1) while the scanner control signal ($\overline{\text{SCAN}}_x$) is low.

$\overline{\text{S/M}}$: S/M: Indicates the mode that is set.

(HIGH: single mode; LOW: multi-mode)

$\overline{\text{MDE}}$: LOW indicates that a mode error occurred.

3.4 Control Method

3.4.1 When Connected to a 3153 AUTOMATIC INSULATION/WITHSTANDING HiTESTER

The scanner settings are made through the 3153's program function. For details on the program function, refer to the operation manual for the 3153 AUTOMATIC INSULATION/WITHSTANDING HiTESTER.

3.4.2 When Connected to a Device Other Than the 3153 AUTOMATIC INSULATION/WITHSTANDING HiTESTER



- In capacitance load testing, etc., an electric charge may still exist even if the voltage on the high-voltage cord is cut off. Be aware of the possible danger of an electric shock.
 - In order to avoid damage to the relays (formation of deposits, etc.), do not turn the relays on or off while voltage is being applied to the high-voltage input cord. This is not a problem when using the 3153 AUTOMATIC INSULATION/WITHSTANDING HiTESTER, because that unit is equipped with a discharge function.
 - In order to avoid electric shock, allow at least 6ms to elapse after turning on a relay before applying voltage to the high-voltage input cord.
The relays used in the 3930 require approximately 6 ms for the contact to completely close or open. When stopping a test, cut off the voltage and allow the test terminal voltage to reach the SELV* before turning a relay off. If a relay is turned on or off while high-voltage current is flowing through it, deposits may form on the relay, ultimately allowing voltage to be output from an unexpected source.
- *: SELV (separated external low voltage): effective value of 30 V, peak value of 42.4 V

Carefully read Chapter 2, "Test Preparation," before connecting the 3930 to the master unit and to the device to be tested. Once all connections are made, the 3930 is controlled through the timing of the address lines, the data lines, and the scanner control signals.

1. Load the 3930 status information (address \$4), and confirm that there is no mode error or ID error, and that the mode is set correctly.
If a mode error or an ID error is detected, stop testing and correct the cause of the error.
2. With no voltage applied to the 3930's high-voltage input cord, the data lines and the scanner control signals are used according to the prescribed timing to turn on the relay for the channel from which output is desired. When the relay turns on, the front LED lights.
(High-voltage output: red; COM connection: green)
3. Apply voltage to the 3930's high-voltage input cord and begin testing.
The voltage that is applied to the high-voltage input cord is output on the specified channel through the relay that turned on.
4. Cut off the voltage that was applied to the 3930's high-voltage input cord and end the test.
5. With no voltage applied to the 3930's high-voltage input cord, the data lines and the scanner control signals are used according to the prescribed timing to control the relay for the next test.
6. Repeat steps 2 through 5 until the series of tests is completed.

Chapter 4

Specifications

(1) Function

Operation mode	Multi/ Single mode
Mode setting method	External switch
Number of channels	Multi mode: HIGH/LOW each 4 channels Single mode: HIGH 8channels - COM
Rated voltage for use	AC/DC 5 kV (rms)
Dielectric strength	10 kVAC, 10 mA, 1 minute between high voltage terminal and frame
Operation display	Lamp lights when power is supplied Lamp lights for specified channel operation
Control method	General control

(2) Relay

Maximum open/close voltage	DC 5000 V/ AC 5000 V (rms)
Maximum open/close current	1 A
Contact resistance between contact points	500 mΩ or less (when 1 mA of current is flowing)
Maximum contact capacitance	50 W
Operation time	6 ms or less
Recovery time	6 ms or less

(3) Control Signal

Digital control signal level	The isolation power supply (between ISO_V - ISO_COM) for determining the signal level is input from an external source. V_{ISO_V} can be selected in a range from 5 to 24 V.
Input signal level	
HIGH	Max.: $V_{ISO_V} + 1$ (V), Min.: $V_{ISO_V} - 1.5$ (V)
LOW	Max.: $V_{ISO_V} - 4.0$ (V), Min.: $V_{ISO_COM} - 0.5$ (V)
Output signal level	
HIGH	Max.: V_{ISO_V} (V), Min.: $V_{ISO_V} - 0.5$ (V)
LOW	Max.: $V_{ISO_COM} + 0.5$ (V), Min.: $V_{ISO_COM} - 0.5$ (V)

(4) Accuracy

Operating temperature and humidity for guaranteed accuracy:

23°C, 80%RH or less

Stipulations for leak current when voltage is applied

For both AC and DC, in single mode, without the 9615-01 or 9615-02 H.V.

TEST LEAD, and all output relays on:

When DC is applied (1000V): 0.1 µA/unit or less

When AC is applied (5 kV, 50 Hz, 60 Hz): 0.4 mA/unit or less

*: Subject to change according to the state of the 9615-01 or 9615-02 H.V.

TEST LEAD

(5) General Specifications

Operating temperature and humidity	0 to 40°C (32 to 104°F), 80% RH or less (no condensation)
Storage temperature and humidity	-10 to 50°C (14 to 122°F), 90% RH or less (no condensation)
Operating Environment	Indoors, max. 2000 m (6562 feet) height
Power supply	V _{SCV} DC24 V (input: control input connector) (a change in voltage of ±10% taken into consideration)
Maximum rated power	12 VA
Calibration cycle	1 year
Accessories	Control input connector connection cable 9615-01 H.V. TEST LEAD (HIGH side) X 8 9615-02 H.V. TEST LEAD (LOW side) X 1 Grounding cable Instruction manual
Dimensions	Approx. 316W X 100H X 350D mm (12.44"W X 3.94"H X 13.78"D) (excluding projections)
Mass	Approx. 4.2 kg (148.1 oz.)
Standard Applying EMC Safety	EN61326 Class A EN61010 Power supply: Pollution Degree 2 (anticipated transient overvoltage 330 V)
Product warranty period	3 years

Chapter 5

Maintenance and Service

5.1 Maintenance and Inspection

To ensure the safe operation of this unit, perform maintenance regularly.

- Be sure to read assiduously the various items highlighted in this manual for attention, in order to use the unit correctly.
- If the unit has been subject to moisture, or if oil and dust have accumulated in the unit interior, the danger of electrical shock or fires resulting from the deterioration of insulation increases greatly. If the unit is ever subject to excessive moisture, oil, or dust, cease use immediately, and return the unit to us for maintenance.
- Spare and replacement parts for this product are guaranteed to be available only until 5 years after manufacture of this model is terminated.

If damage is suspected, check the "Troubleshooting" section before contacting your dealer or Hioki representative.

Symptom	What to check and Solution
Power does not come on	<ul style="list-style-type: none"> • Is the control input connector connected correctly? • Is the master unit power on? • Is the correct power supply voltage being used? • Is the power supply connected?
LED is dark or flashes	Is the current capacity of the SCV power supply adequate?
Unit is not controlled as expected	<ul style="list-style-type: none"> • Is the ISO_V power supply connected correctly? • Is the control signal level correct? • Is the scanner control signal with the same ID number being used? • Is the control timing correct? • Is the control connector connected correctly?
No voltage is output	<ul style="list-style-type: none"> • Is the high-voltage input cord connected? • Did a mode error occur?

5.2 Cleaning

To clean the product, wipe it gently with a soft cloth moistened with water or mild detergent. Never use solvents such as benzene, alcohol, acetone, ether, ketones, thinners or gasoline, as they can deform and discolor the case.

Warranty Certificate

HIOKI

Model	Serial number	Warranty period Three (3) years from date of purchase (___ / ___)
-------	---------------	--

Customer name: _____

Customer address: _____

Important

- Please retain this warranty certificate. Duplicates cannot be reissued.
- Complete the certificate with the model number, serial number, and date of purchase, along with your name and address. The personal information you provide on this form will only be used to provide repair service and information about Hioki products and services.

This document certifies that the product has been inspected and verified to conform to Hioki's standards.

Please contact the place of purchase in the event of a malfunction and provide this document, in which case Hioki will repair or replace the product subject to the warranty terms described below.

Warranty terms

1. The product is guaranteed to operate properly during the warranty period (three [3] years from the date of purchase).
If the date of purchase is unknown, the warranty period is defined as three (3) years from the date (month and year) of manufacture (as indicated by the first four digits of the serial number in YYMM format).
2. If the product came with an AC adapter, the adapter is warranted for one (1) year from the date of purchase.
3. The accuracy of measured values and other data generated by the product is guaranteed as described in the product specifications.
4. In the event that the product or AC adapter malfunctions during its respective warranty period due to a defect of workmanship or materials, Hioki will repair or replace the product or AC adapter free of charge.
5. The following malfunctions and issues are not covered by the warranty and as such are not subject to free repair or replacement:
 - 1. Malfunctions or damage of consumables, parts with a defined service life, etc.
 - 2. Malfunctions or damage of connectors, cables, etc.
 - 3. Malfunctions or damage caused by shipment, dropping, relocation, etc., after purchase of the product
 - 4. Malfunctions or damage caused by inappropriate handling that violates information found in the instruction manual or on precautionary labeling on the product itself
 - 5. Malfunctions or damage caused by a failure to perform maintenance or inspections as required by law or recommended in the instruction manual
 - 6. Malfunctions or damage caused by fire, storms or flooding, earthquakes, lightning, power anomalies (involving voltage, frequency, etc.), war or unrest, contamination with radiation, or other acts of God
 - 7. Damage that is limited to the product's appearance (cosmetic blemishes, deformation of enclosure shape, fading of color, etc.)
 - 8. Other malfunctions or damage for which Hioki is not responsible
6. The warranty will be considered invalidated in the following circumstances, in which case Hioki will be unable to perform service such as repair or calibration:
 - 1. If the product has been repaired or modified by a company, entity, or individual other than Hioki
 - 2. If the product has been embedded in another piece of equipment for use in a special application (aerospace, nuclear power, medical use, vehicle control, etc.) without Hioki's having received prior notice
7. If you experience a loss caused by use of the product and Hioki determines that it is responsible for the underlying issue, Hioki will provide compensation in an amount not to exceed the purchase price, with the following exceptions:
 - 1. Secondary damage arising from damage to a measured device or component that was caused by use of the product
 - 2. Damage arising from measurement results provided by the product
 - 3. Damage to a device other than the product that was sustained when connecting the device to the product (including via network connections)
8. Hioki reserves the right to decline to perform repair, calibration, or other service for products for which a certain amount of time has passed since their manufacture, products whose parts have been discontinued, and products that cannot be repaired due to unforeseen circumstances.

HIOKI E.E. CORPORATION

<http://www.hioki.com>

18-07 EN-3

HIOKI

<http://www.hioki.com>



**All regional
contact
information**

HEADQUARTERS

81 Koizumi
Ueda, Nagano 386-1192 Japan

HIOKI EUROPE GmbH

Rudolf-Diesel-Strasse 5
65760 Eschborn, Germany
hioki@hioki.eu

1906 EN

Edited and published by HIOKI E.E. CORPORATION

Printed in Japan

- CE declarations of conformity can be downloaded from our website.
- Contents subject to change without notice.
- This document contains copyrighted content.
- It is prohibited to copy, reproduce, or modify the content of this document without permission.
- Company names, product names, etc. mentioned in this document are trademarks or registered trademarks of their respective companies.