

# SM9060

## SMD TEST FIXTURE

### Instruction Manual

EN

Aug. 2016 Revised edition 1 Printed in Japan

SM9060A961-01 16-08H



**HIOKI**

www.hioki.com/

HIOKI E.E. CORPORATION  
81 Koizumi, Ueda, Nagano 386-1192 Japan



All regional contact information

2309 EN

Edited and published by HIOKI E.E. CORPORATION Printed in Japan

• Contents subject to change without notice.  
• This document contains copyrighted content.  
• It is prohibited to copy, reproduce, or modify the content of this document without permission.  
• Company names, product names, etc. mentioned in this document are trademarks or registered trademarks of their respective companies.

Europe only  
• EU declaration of conformity can be downloaded from our website.  
• Contact in Europe: HIOKI EUROPE GmbH  
Helfmann-Park 2, 65760 Eschborn, Germany hioki@hioki.eu

### Warranty

Warranty malfunctions occurring under conditions of normal use in conformity with the Instruction Manual and Product Precautionary Markings will be repaired free of charge. This warranty is valid for a period of one (1) year from the date of purchase. Please contact the distributor from which you purchased the product for further information on warranty provisions.

### Introduction

Thank you for purchasing the Hioki SM9060 SMD Test Fixture. To obtain maximum performance from the device, please read this manual first, and keep it handy for future reference.

### Verifying Package Contents

When you receive the device, inspect it carefully to ensure that no damage occurred during shipping. In particular, check the connectors. If damage is evident, or if it fails to operate according to the specifications, contact your authorized Hioki distributor or reseller.

### Precautions during shipment

- Store the packaging in which the device was delivered, as you will need it when transporting the device.
- To avoid damage to the device, remove the cables from the device. Moreover, use the original packing materials in which it was shipped, and be sure to pack in a double carton. Damage occurring during transportation is not covered by the warranty.
- When sending the device for repair, be sure to include details of the problem.

### Disposal

Handle and dispose of the device in accordance with local regulations.

### Cleaning

- DUT holder (stage)  
Clean the DUT holder periodically. Move the operating lever to the **OPEN** position, open the safety cover, and then brush gently the DUT holder (stage) back and forth a couple of times with the supplied cleaning brush.
- Other Precaution  
To clean the device, wipe it gently with a soft cloth moistened with water or mild detergent.

### Troubleshooting

If you are unable to make measurement even after cleaning the DUT holder (stage) with the supplied cleaning brush, confirm that the cables are not open circuited before contact your authorized Hioki distributor or reseller.

## Overview

This test fixture, which supports 008004/0201 (imperial/metric, respectively) size chip capacitors, can measure insulation resistance values of chip capacitors by using in combination with Hioki Super Megohm Tester.

The DUT holder (stage) is lowered to separate from a DUT prior to a measurement, providing precise insulation resistance measurement with no influence from any leakage current flowing via the DUT folder.

## Safety Notes

Before using the device, be certain to carefully read the following safety notes:

### DANGER

- **Mishandling during use could result in injury or death, as well as damage to the device. Be certain that you understand the instructions and precautions in the manual before use.**

### WARNING

- **With regard to the electricity supply, there are risks of electric shock, heat generation, fire, and arc flash due to short circuits. Individuals using an electrical measuring device for the first time should be supervised by a technician who has experience in electrical measurement.**

### Notation

In this manual, the risk seriousness and the hazard levels are classified as follows.

<b>DANGER</b>	Indicates an imminently hazardous situation that will result in death or serious injury to the operator.
<b>WARNING</b>	Indicates a potentially hazardous situation that may result in death or serious injury to the operator.
<b>CAUTION</b>	Indicates a potentially hazardous situation that may result in minor or moderate injury to the operator or damage to the device or malfunction.



Indicates prohibited actions.



Indicates the action which must be performed.

### Symbols on the device, Symbols for various standards



Indicates cautions and hazards. When the symbol is printed on the device, refer to a corresponding topic in the Instruction Manual.



Indicates DC (Direct Current).

## Usage Notes

Follow these precautions to ensure safe operation and to obtain the full benefits of the various functions.

### DANGER

- **Do not short-circuit the tips of the probes each other. Doing so could result in a serious accident such as ark flash.**

### WARNING

**Installing the device in inappropriate locations may cause a malfunction of device or may give rise to an accident. Avoid the following locations:**

- Exposed to direct sunlight or high temperature
  - Exposed to corrosive or combustible gases
  - Exposed to a strong electromagnetic field or electrostatic charge
  - Near induction heating systems (such as high-frequency induction heating systems and IH cooking equipment)
  - Susceptible to vibration
  - Exposed to water, oil, chemicals, or solvents
  - Exposed to high humidity or condensation
  - Exposed to high quantities of dust particles
- **The maximum input voltage of the device is 300 V. Do not use the device with circuits that exceed its ratings or specifications. Doing so may damage the device or cause it to become hot, resulting in electric shock.**
  - **Customers are not allowed to modify, disassemble, or repair the device. Doing so may cause fire, electric shock, or injury.**

### CAUTION

- **To avoid damage to the device, protect it from physical shock when transporting and handling. Be especially careful to avoid physical shock from dropping.**

## Specifications

<b>Connectable measurement instruments</b>	Models SM7110 and SM7120 Super Megohm Meter (As of July 2016) For updated information about connectable instruments, contact your authorized Hioki distributor or reseller.
<b>Operating environment</b>	Indoors, altitude up to 2000 m (6562 ft.)
<b>Operating temperature and humidity</b>	0°C to 40°C (32°F to 104°F), 80% RH or less (no condensation)
<b>Storage temperature and humidity</b>	-10°C to 55°C (14°F to 131°F), 80% RH or less (no condensation)
<b>Dimensions</b>	Approx. 139.5W × 52.5H × 116D mm (5.49"W × 2.07"H × 4.57"D) (Excluding operating lever, connecting terminals, and micrometer head)
<b>Mass</b>	Approx. 600 g (21.2 oz.)
<b>Product warranty period</b>	1 year
<b>Connecting terminals</b>	OUTPUT terminal: Banana jack INPUT terminal: Triaxial BNC connector INTERLOCK terminal: BNC connector
<b>Contact section with DUT</b>	2-terminal design The probes come into contact with side terminals of an SMD.
<b>Measurable DUT dimensions</b>	0.25±20% × 0.125±10% × 0.125±10% mm (Based on EIA: 008004, based on JIS: 0201)
<b>Input voltage</b>	Up to 300 V
<b>Measurable range of insulation resistance</b>	Complying with an measurement instrument to which the device connects
<b>Probe material</b>	MF20 (micro-grain cemented carbide)
<b>Contact pressure applied to DUT</b>	0.22 N (23 gf) or less
<b>Setting method for distance between measurement terminals</b>	Micrometer head with graduations of 0.01 mm
<b>Accessories</b>	• Instruction Manual • Cleaning brush for DUT holder (stage) • Connection cable (for INPUT terminal, 1 m) • Connection cable (for OUTPUT terminal, 1 m) • Interlock cable (BNC-BNC, 1.5 m)

# Part Names

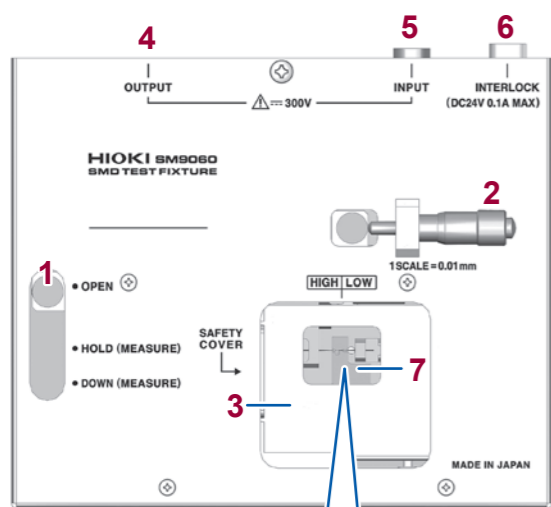

## Enlarged view of the measurement section

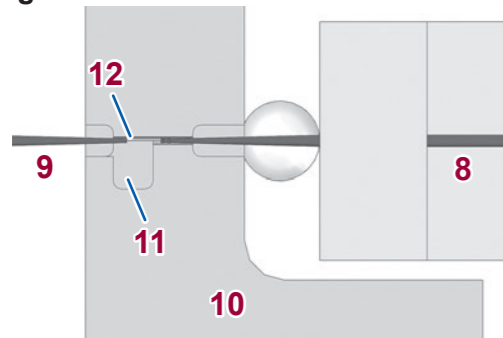

1	Operating lever
2	Micrometer head (Travel distance: one graduation = 0.01 mm, one complete turn = 0.5 mm)
3	Safety cover
4	Connecting terminals to measurement instrument
5	OUTPUT terminal: banana jack ⚠
6	INPUT terminal: Triaxial BNC connector ⚠
7	INTERLOCK terminal: BNC connector
8	Measurement section
9	Measurement probe (fixed side)
10	Measurement probe (movable side)
11	DUT holder (stage)
12	Temporary placing table
13	Guide groove

# Connection Procedure

## Inspection Before Use

Before using the device, verify that it operates normally to ensure that no damage occurred during storage or shipping. If you find any damage, contact your authorized Hioki distributor or reseller.

Check item	Remedy
Is the cable insulation torn?	If there is any damage, electric shock may result. Discontinue use and contact your authorized Hioki distributor or reseller.
Does the measurement probe (movable side) move from side to side when you move the operating lever between <b>OPEN</b> and <b>HOLD (MEASURE)</b> ?	If you find any damage, contact your authorized Hioki distributor or reseller.
Does the DUT holder (stage) move up and down when you move the operating lever between <b>HOLD (MEASURE)</b> and <b>DOWN (MEASURE)</b> ?	

## CAUTION

To prevent damage to the BNC connector, be sure to release the locking mechanism, grip the head of the connector (not the cord), and pull it out.

## Example of the connection (when connecting device to Model SM7120)

Refer to the instrument's instruction manual to connect the device to the instrument.

### You will need the followings:

1. Connection cable (for OUTPUT terminals)
2. Connection cable (for INPUT terminals)
3. Interlock cable (BNC-BNC)

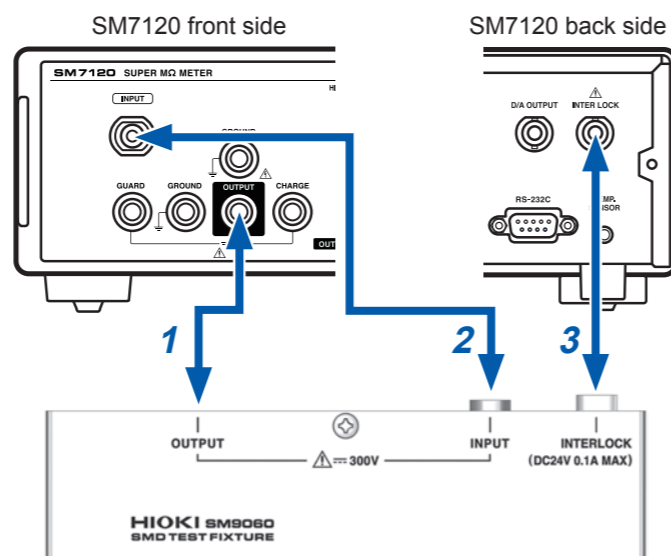

1 Attach the connection cable (for OUTPUT terminals) to the OUTPUT terminal.

2 Attach the connection cable (for INPUT terminals) to the INPUT terminal.

(1) Check the orientation of the grooves in the BNC connector and ensure that they fit into the bayonet lugs of the connector on the SM9060.

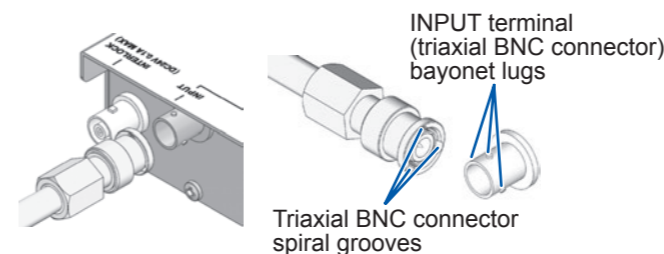

(2) Attach the BNC connector of the cable to the connector on the SM9060, aligning the spiral grooves in the BNC connector along the bayonet lugs of the connector on the SM9060, and turn the coupling nut clockwise to lock it.



3 Attach the interlock cable (BNC-BNC) to the INTERLOCK terminal.

1 Align them with each other and insert the connector.

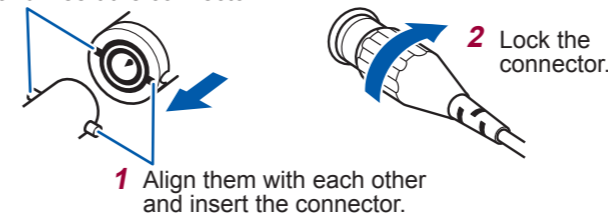

## INTERLOCK terminal

When the INTERLOCK terminal, which is connected to the switch interlocking with the safety cover, is connected with the instrument, the device behaves as the followings:

- The measurement voltage is input when the safety cover is closed.
- No measurement voltage is input when the safety cover opens.

The interlock function, which prevents a high voltage from being input, provides safe measurement.  
Rating of the switch for the INTERLOCK: 24 V DC, 0.1 A

## CAUTION

If the interlock function of the instrument is disabled, the measurement voltage will be applied even with the safety cover open. Touching a probe or metal parts inside of the cover may cause an electric shock in this state.

## Adjusting distance between measurement probes

When the operating lever is at the **CLOSE (MEASURE)** position, the distance between the measurement probes can be adjusted using the micrometer head. (Travel distance: one graduation = 0.01 mm, one complete turn = 0.5 mm)

Recommended distance: (DUT length) - 0.1 mm

- 1 Move the control lever to the **HOLD (MEASURE)** position.
- 2 Turn the thimble to adjust the distance between the probes.

Turn the thimble clockwise or counter-clockwise to shorten or lengthen the distance between the probes, respectively.

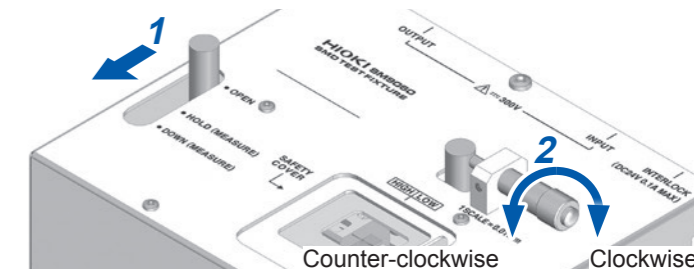

## CAUTION

- The probes cannot fix a DUT firmly if the distance between the probes is adjusted to be equal to or more than the DUT length.
- If the distance between terminals is adjusted to less than the recommended distance, the probes will be short-circuit each other when the DUT drops.

# Performing Measurement

You will need a pair of tweezers

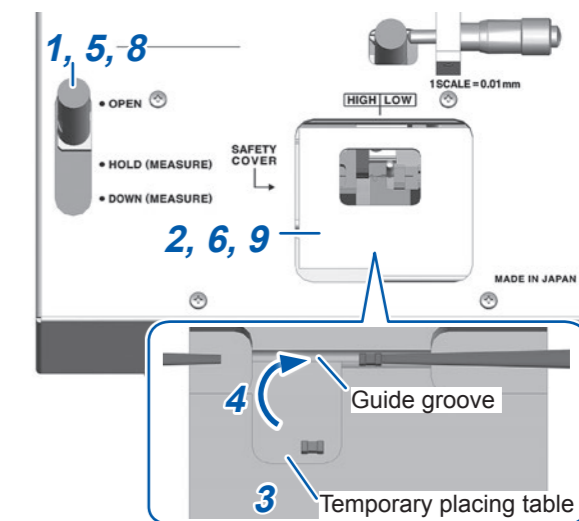

- 1 Move the operating lever to the **OPEN** position.
- 2 Open the safety cover with the tweezers.
- 3 Place a DUT on the temporary placing table with the tweezers.
- 4 Move the DUT to the guide groove with the tweezers.
- 5 Move the operating lever from the **OPEN** position to the **DOWN (MEASURE)** position via the **HOLD (MEASURE)** position.
- 6 Close the safety cover.
- 7 Measure the insulation resistance of the DUT with the instrument.
- 8 Move the operating lever to the **OPEN** position.
- 9 Open the safety cover.
- 10 Take away the DUT.