

HIOKI

Instruction Manual

9203

DIGITAL PRINTER

HIOKI E. E. CORPORATION

May 2012 Revised edition 11 9203A981-11 12-05H



60019496B

Contents

Introduction	1
Inspection	1
Safety Notes	2
Precautions	3
Maintenance	5
Chapter 1 Overview	7
1.1 Names and Functions of Parts	7
1.1.1 Front Panel	7
1.1.2 Side Panel	9
Chapter 2 Setting Up the Unit	11
2.1 Interface Connections	11
2.2 Loading Recording Paper	14
2.3 Self-Test	16
2.4 Adjusting the Display Contrast	17
Chapter 3 Mode Settings	19
3.1 Menu Screen	19
3.2 Print Setting Screen	20
3.3 Statistics Setting Screen	22
3.4 Histogram Setting Screen	23
3.5 Time Setting Screen	25
3.6 Flowchart of Setting Screens	25
Chapter 4 Printing Operations	27
4.1 Starting Printing	27
4.2 Ending Printing	31
4.3 Cancel Function	31
Chapter 5 Printing Details	33
5.1 Statistical Processing	33
5.2 Histograms	35
5.3 Graphs	37

Chapter 6 Other Functions	39
6.1 System Reset	39
6.2 Error Indications	40
Chapter 7 External I/O Terminals	41
7.1 Terminals	41
7.2 Ground Terminal	42
7.3 Output Terminals	42
7.4 Input Terminals	43
Chapter 8 Specifications	45
Chapter 9 Maintenance and Servicing	51
9.1 Power Fuse Replacement	51
9.2 Ultimate Disposal	53

Introduction

Thank you for purchasing the HIOKI "9203 DIGITAL PRINTER." To obtain maximum performance from the product, please read this manual first, and keep it handy for future reference.

Inspection

When you receive the product, inspect it carefully to ensure that no damage occurred during shipping. In particular, check the accessories, display panel and operating keys. If damage is evident, or if it fails to operate according to the specifications, contact your dealer or Hioki representative.

NOTE

- The 9203 is a special-purpose printer for use with the following HIOKI products only. Do not connect it to other products.

3227 m HiTESTER

3540 m HiTESTER

3560 AC m HiTESTER

3550 BATTERY HiTESTER

3551 BATTERY HiTESTER

In the instruction manual, the 3227, 3540, and 3560 are all referred to as "m HiTESTERs," and the 3550 and 3551 are referred to as "BATTERY HiTESTERs."

- For connection to the 3227 or 3560 instrument, a 9589 PRINTER INTERFACE and 9425 CONNECTION CABLE are required.
- For connection to the 3540, 3550 or 3551 instrument, a 9425 CONNECTION CABLE is required.

Safety Notes



This product is designed to comply with IEC 61010 Safety Standards, and has been thoroughly tested for safety prior to shipment. However, mishandling during use could result in injury or death, as well as damage to the product. Be certain that you understand the instructions and precautions in the manual before use. We disclaim any responsibility for accidents or injuries not resulting directly from product defects.

The following symbols in this manual indicate the relative importance of cautions and warnings.

	Indicates that incorrect operation presents a significant hazard that could result in serious injury or death to the user.
	Indicates that incorrect operation presents a possibility of injury to the user or damage to the product.
	Indicates advisory items related to performance or correct operation of the product.

Safety symbols

This manual contains information and warnings essential for safe operation of the product and for maintaining it in safe operating condition. Before using it, be sure to carefully read the following safety precautions.

	<p>The symbol printed on the product indicates that the user should refer to a corresponding topic in the manual (marked with the symbol) before using the relevant function.</p> <p>In the manual, the symbol indicates particularly important information that the user should read before using the product.</p>
	Indicates a fuse.
	Indicates AC (Alternating Current).

Precautions

⚠ WARNING

- Before turning the product on, make sure the supply voltage matches that indicated on the its power connector. Connection to an improper supply voltage may damage the product and present an electrical hazard.
- The product is constructed so as to be connected to a ground line via a three-core power cord that is supplied with the product.
- To avoid electrical accidents and to maintain the safety specifications of this instrument, connect the power cord only to a 3-contact (two-conductor + ground) outlet.
- Do not use the product where it may be exposed to corrosive or combustible gases. The product may be damaged or cause an explosion.

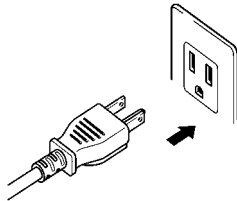

Insert the plug into the outlet.

⚠CAUTION

- To avoid damage to the product, protect it from physical shock when transporting and handling. Be especially careful to avoid physical shock from dropping.
- Do not store or use the product where it could be exposed to direct sunlight, high temperature or humidity, or condensation. Under such conditions, the product may be damaged and insulation may deteriorate so that it no longer meets specifications.
- Do not use the product near a source of strong electromagnetic radiation, or near a highly electrically charged object. These may cause a malfunction.
- This product is not designed to be entirely water- or dust-proof. Do not use it in an especially dusty environment, nor where it might be splashed with liquid. This may cause damage.

NOTE

- This product uses a thermal print head, using selected thermal recording paper. Use only the correct recording paper: HIOKI 9233 RECORDING PAPER.
- The thermal recording technique uses a thermochemical reaction in the recording paper. Note the following points on handling recording paper and recordings carefully.

Handling recording paper and recordings

Storing recording paper

- Store rolls of thermal paper at not more than 40 °C.
- The paper will change color if exposed to light over a long period, so do not unwrap a roll of paper until you are ready to use it.

Storing data recordings

As the recording paper is thermally sensitive, be aware of the following points:

- To avoid paper discoloration, do not expose it to direct sunlight, and store at no more than 40 °C and 90% RH.
- For permanent storage of important recorded data, photocopy the recording paper.
- If the thermal paper is exposed to an organic solvent such as alcohol or ketone, it may no longer develop properly, and recorded data may fade.
- Also, the thermal recording paper is ruined by contact with wet Daizo copy paper.

Maintenance

To clean the product, wipe it gently with a soft cloth moistened with water or mild detergent. Never use solvents such as benzene, alcohol, acetone, ether, ketones, thinners or gasoline, as they can deform and discolor the case.

Chapter 1

Overview

This product is a digital printer, also equipped with functions for statistical calculations such as standard deviation and printing histograms. It can be exploited for data analysis and management.

1.1 Names and Functions of Parts

1.1.1 Front Panel

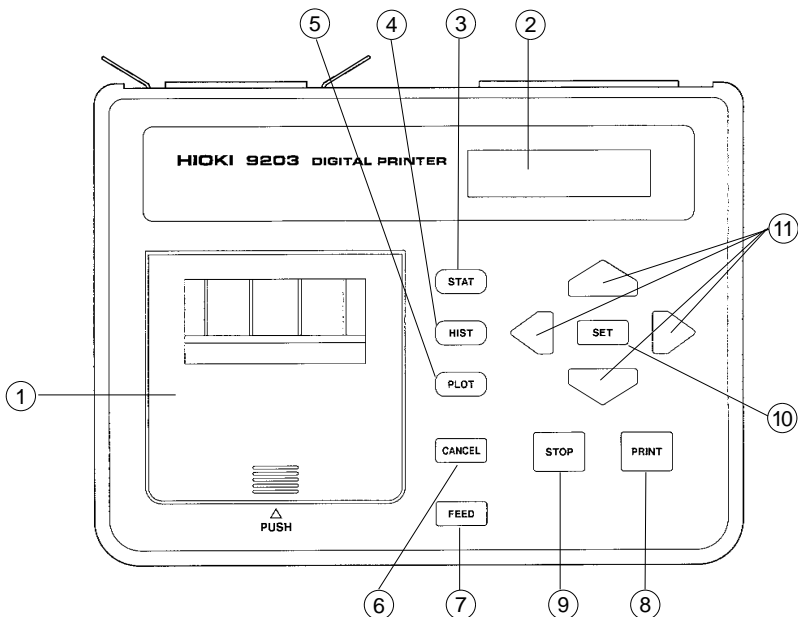

- ① Recording paper compartment
Insert a roll of recording paper.
- ② LCD display
This shows various settings and the printer status.
- ③ STAT key
Press this to compute and print the statistics for the input data.
- ④ HIST key
Press this to print a histogram of the input data.
- ⑤ PLOT key
Press this to print a time-series graph of the input data.
- ⑥ CANCEL key
Press this to cancel the immediately previous input data or press of the STOP key.
- ⑦ FEED key
Press this to feed the recording paper.
- ⑧ PRINT key
Press this to capture measurement data into the printer.
- ⑨ STOP key
During input of measurement data, pressing this key stops the input of data, and prints the statistics for the data input so far. At other times, pressing this key stops whatever printing is in progress.
- ⑩ SET key
Press this to confirm a setting in the setting screen.
- ⑪ Adjustment keys
Press these to move the cursor in the setting screen and to adjust setting values.

1.1.2 Side Panel

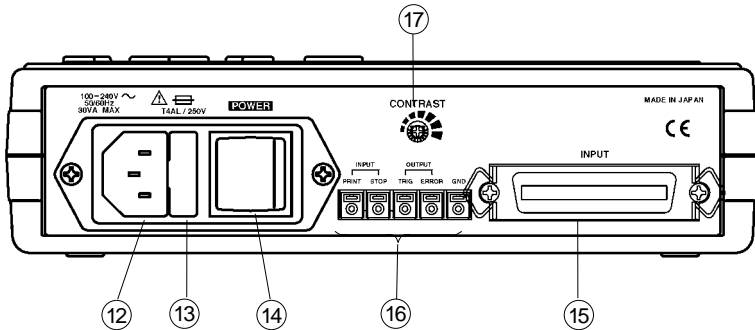

⑫ Power inlet

Plug in the power cord.

⑬ Power fuse holder

This holds the power fuse and also contains a spare fuse.

⑭ POWER switch

This powers the product on and off.

⑮ Connection cable connector

Connect the 9425 CONNECTION CABLE.

⑯ External I/O terminals

GND This is the ground terminal for the external I/O terminals.

TRIG The print trigger from this product is output.

ERROR If there is a fault in the printer, a signal is output from this terminal.

PRINT Inputs a print command signal. (Same effect as pressing the PRINT key.)

STOP Inputs a stop command signal. (Same effect as pressing the STOP key.)

NOTE

The GND and TRIG terminals are used with the supplied connection leads, to connect to the m HiTESTER.

⑰ Contrast adjustment knob

Turn this to adjust the contrast of the LCD display.

Chapter 2

Setting Up the Unit

2.1 Interface Connections

**WARNING**

To avoid shock and short circuits, turn off all power before connecting the product.

NOTE

- For connection to the 3227 or 3560 instrument, a 9589 PRINTER INTERFACE and 9425 CONNECTION CABLE are required. For details of the procedure for installing the 9589 in the tester, refer to the Instruction Manual for the tester.
- For connection to the 3540, 3550 or 3551 instrument, a 9425 CONNECTION CABLE is required.

1. Interface connections

Use a 9425 CONNECTION CABLE (option) to connect the 9203 to the printer connector of the tester.

Use the supplied connection leads to connect the 9203 to the m HiTESTER. For details of the connection, see Chapter 7, "External I/O Terminals."

(1) Connection to the m HiTESTER (figure: 3227)

- When connecting the 9203 to the m HiTESTER only Use the supplied connection leads to connect the TRIG terminal of the 9203 to the PRINT terminal of the m HiTESTER, and the GND terminals of both the units.

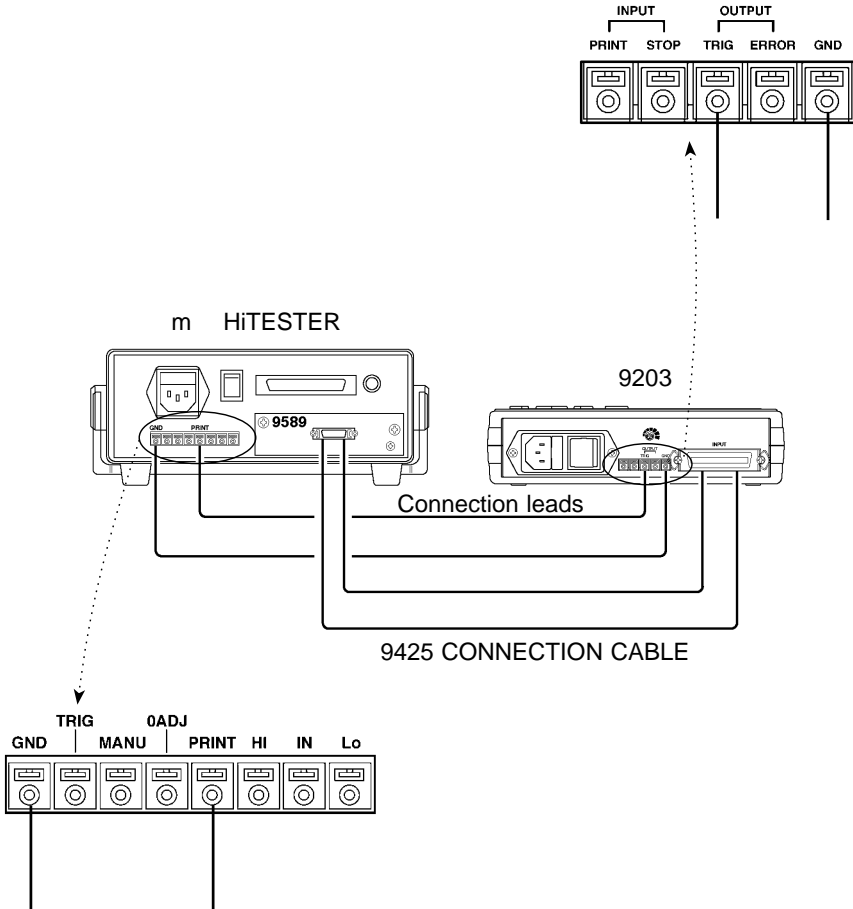

- When controlling using the controller

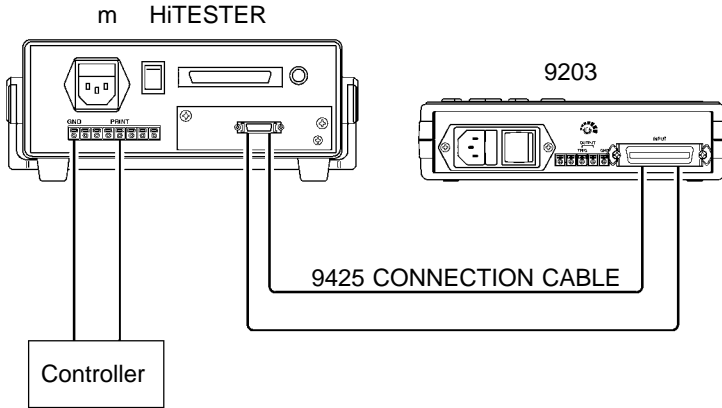

NOTE

The trigger signals of the 9203 are controlled by the internal timer, so they can be output only at intervals of 1 second. Therefore, when printing at intervals of less than 1 second, or when synchronizing printing with the m HiTESTER measurement, make connections as shown in the figure above.

(2) Connection to the BATTERY HiTESTER

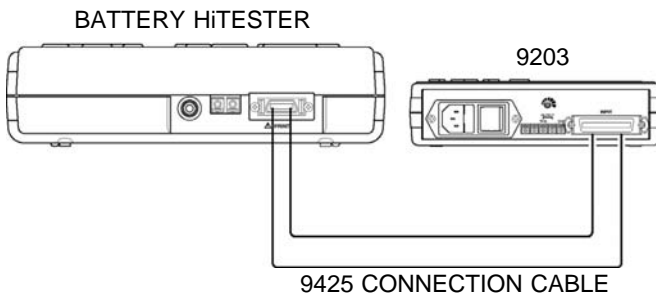

2. Powering on

Power on both the tester and the 9203.

2.2 Loading Recording Paper

1. Press the cover of the recording paper compartment, as shown in the figure, then open the cover.

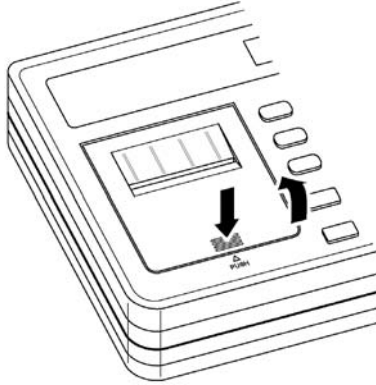

2. Raise the printer head, then feed the end of the recording paper fully through the paper path, so that the paper projects adequately from the printer.
It is easier to do this if you first trim the end of the paper to a point.

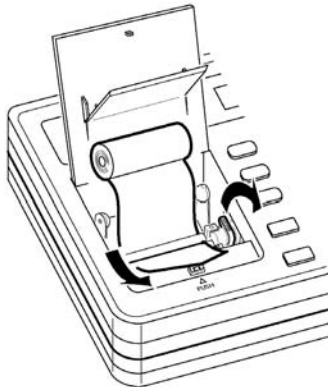

3. Lower the printer head.

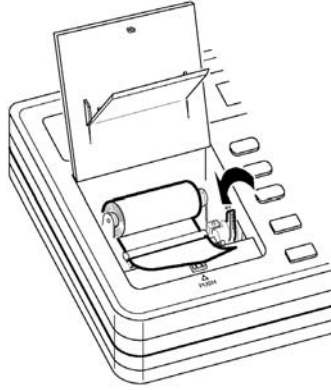

4. Feed the paper through the cutter, then close the cover.

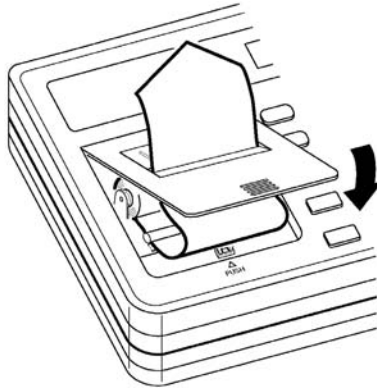

2.3 Self-Test

When powered on, the product carries out a self-test. After being powered on, the model number and version appear in the LCD display, and if the result of the self-test is normal, next the menu screen appears.



Ver. 2.00

If the self-test procedure finds a fault, a display like the following one appears.



HEAD UP
PAPER END

- | | |
|------------------|--|
| (1) ROM ERROR | There is a fault in the product, and repair is required. |
| (2) RAM ERROR | There is a fault in the product, and repair is required. |
| (3) HEAD UP | The printer head is raised. |
| (4) PAPER END | There is no recording paper. |
| (5) MISS CONNECT | Either nothing is connected to this product, or there is an error in the interface connection. |

2.4 Adjusting the Display Contrast

Turn the contrast adjustment knob on the side panel to adjust the contrast of the LCD display.

CONTRAST



Chapter 3

Mode Settings

3.1 Menu Screen

From the menu screen you can access the various settings.



◀ ▶ keys Move the flashing cursor, to select the setting screen.

▽ key Switch to the setting screen indicated by the cursor.

- (1) PRINT Switch to the print setting screen. This selects the data to be printed, the printing interval, and the time to be printed (real or elapsed).
- (2) STAT Switch to the statistics setting screen. This sets the upper and lower limits required for calculating C_p and C_{pK} .
- (3) HISTOGRAM Switch to the histogram setting screen. This selects the conditions for drawing histograms.
- (4) TIME Switch to the time setting screen. This sets the current date and time in the product.

3.2 Print Setting Screen

In this screen, select the data to be printed, the printing interval, and the time to be printed (real or elapsed).

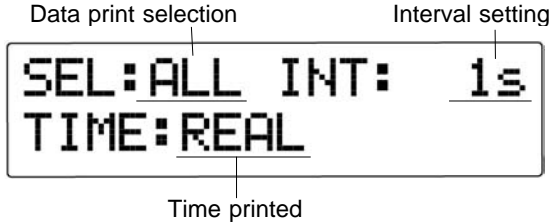

- ◀ ▶ keys Move the flashing cursor, to select the item to set.
- ▼ ▲ keys Change the setting of the selected item.
- SET key Return to the menu screen.

NOTE

With the BATTERY HiTESTER, the settings in the print setting screen are ignored.

● Data print selection

The values to be printed are selected on the basis of the comparator result provided by the m HiTESTER. (The data input to the printer is held in memory as measurement data.)

- (1) ALL Print all values held in memory.
- (2) HL Print all values in memory for which the comparator result is HI or LO.
- (3) IN Print all values in memory for which the comparator result is IN.
- (4) VAL Print all valid values in memory, that is, for which the measurement result is other than OF (overflow) or NG (measurement failure).
- (5) OFF No printing.

NOTE

When HL or IN is selected, if values in memory do not have associated comparator results, they are not printed.

● Interval setting

Set the interval at which the data input from the m HiTESTER is printed. There are two modes for this setting: manual and auto.

- Manual (MANU) mode

In the manual mode, whenever you press the **PRINT** key, or when a PRINT signal is input, data is input into memory.

- Auto mode

In the auto mode, data is input into memory automatically at the specified interval. In this case, it is still possible to capture additional data values at any time by pressing the **PRINT** key or inputting a PRINT signal.

- | | |
|-------------------------|----------------------------------|
| (1) MANU | Manual mode |
| (2) 1/2/5/10/15/20/30 s | Auto mode (intervals in seconds) |
| (3) 1/2/5/10/15/20/30 m | Auto mode (intervals in minutes) |
| (4) 1h | Auto mode (one hour interval) |

● Time printed

Select the time to be printed together with the m HiTESTER data values.

- | | |
|---------------|--|
| (1) REAL | Print the real time. |
| (2) ACCUMLATE | Print the elapsed time from the beginning of printing. |

NOTE

When the elapsed time is printed, the values cycle round from 23:59:59 to 00:00:00.

3.3 Statistics Setting Screen

In this screen, select the upper and lower limits required for calculating the process productivity index C_p (dispersion) and C_{pK} (bias).

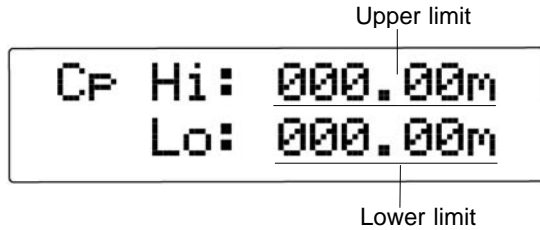

● Setting a numeric value

The numeric value display consists of seven characters: a sign, five digits, and a unit multiple prefix.

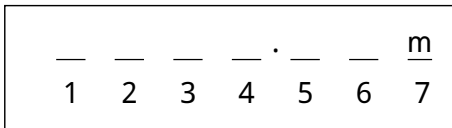

◀ ▶ keys Move the flashing cursor, to select the character position (sign, digit, or prefix) to adjust.

△ ▽ keys Change the setting of the selected character position.

- Character position 1 blank for positive, or minus sign.
- Character positions 2 to 6 digit, 0 to 9.
- Character position 7 adjust the position of the decimal point and the unit prefix as follows.

Using the \triangle key

. m
 .
 .
 .
 . k
 . k
 . k

Using the ∇ key

. k
 . k
 . k
 .
 .
 .
 . m

SET key Return to the menu screen.

3.4 Histogram Setting Screen

In this screen, select the conditions for drawing histograms.

Creation mode Rank width

AUTO	20%(± 5)
CENTER:	000.05m

Center value

\triangle ∇ keys Move the flashing cursor, to select the item to adjust.

\triangle ∇ keys Change the setting of the selected item.

SET key Return to the menu screen.

● **Selecting the creation mode**

This selects the way in which the histogram is created. There are two modes: auto and manual.

- Auto mode

In auto mode, an optimized histogram for the input data is created by automatically determining the center value and rank width.

The minimum and maximum valid data values in memory are found, and their mean used as the center value, then the rank width is adjusted to make all values fit in the histogram.

- Manual (MANU) mode

In manual mode, you can freely specify the center value and rank width. This can be useful for making adjustments after printing the histogram first in auto mode.

NOTE

In auto mode, after once creating a histogram, definitive values for the center value and rank width are entered.

● **Setting the rank width**

Set the rank width as a percentage of the center value.

(1) Rank widths (± 5 ranks)

0.1% (± 5)/ 0.2% (± 5)/ 0.5% (± 5)/ 1% (± 5)/ 2% (± 5)/
5% (± 5)/ 10% (± 5)/ 20% (± 5)

(2) Rank widths (± 10 ranks)

0.1% (± 10)/ 0.2% (± 10)/ 0.5% (± 10)/ 1% (± 10)/
2% (± 10)/ 5% (± 10)/ 10% (± 10)

● **Setting the center value**

Set the center value numerically.

NOTE

Use the same procedure as in the statistics setting screen.

3.5 Time Setting Screen

In this screen, set the current date and time.

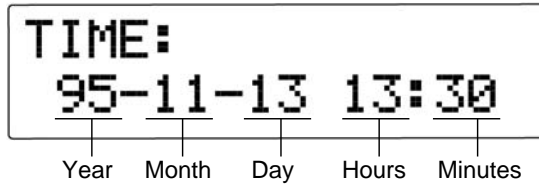

- ◀ ▶ keys Move the flashing cursor, to select the item to adjust.
- △ ▽ keys Change the setting of the selected item.
- SET key Return to the menu screen. The clock is started, with a zero seconds value, at this point.

3.6 Flowchart of Setting Screens

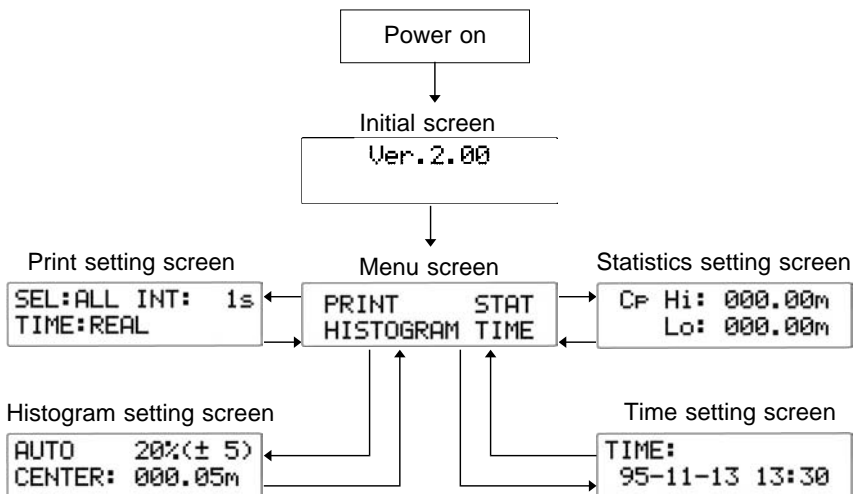

Chapter 4

Printing Operations

4.1 Starting Printing

During printing, the number of values in memory is displayed, as follows.

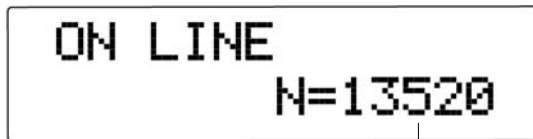

```
ON LINE
      N=13520
```

Number of values

NOTE

If a fault occurs in the printer (head up, or paper end), a signal is output from the ERROR external output terminal, and the product stops operation until the fault is cleared.

If, however, the data print selection is set to "OFF" (i.e. no printing), then operation does not stop.

● With the m HiTESTER

A maximum of 99,999 values can be printed consecutively. If 99,999 values are input into memory, printing stops automatically.

- (1) When the interval setting is "MANU" (manual mode)
Whenever you press the **PRINT** key, or when a PRINT signal is input, capture of data into memory starts. Thereafter, each time you press the **PRINT** key, or a PRINT signal is input, the next data value is captured to memory.
- (2) When the interval setting is "AUTO" (auto mode)
Data capture starts when you press the **PRINT** key, or when a PRINT signal is input. Thereafter, a new value is automatically captured to memory at the specified interval. It is still possible to capture additional values at any time by pressing the **PRINT** key or inputting a PRINT signal.

NOTE

The explanations above are effective when using the supplied connection leads to connect the m HiTESTER to the 9203.

The values are captured to memory by data transfer from the m HiTESTER, when using the 9425 CONNECTION CABLE only without using the connection leads for connection.

● With the BATTERY HiTESTER

After all the values in memory of the BATTERY HiTESTER are printed, printing stops automatically.

After the 9203 stops a printing operation, pressing the **PRINT** key of the BATTERY HiTESTER transfers all the measurement values in memory of the BATTERY HiTESTER to the 9203, and prints them.

● Example of printing (with the m HiTESTER)

Data print setting ALL
 Interval 5 s
 Time printed elapsed time (ACCUMULATE)

	②	③	①	④	⑤	
START/		'98-	5-	8	16:43:03	PRINT key pressed
1	0:00:00			200.00mΩ	IN	Interval print
2	0:00:05			200.00mΩ	IN	Interval print
3	0:00:10			190.00mΩ	Lo	Interval print
4	0:00:15			210.00mΩ	Hi	PRINT key pressed
5	0:00:18			210.00mΩ	Hi	PRINT key pressed
6	0:00:22			200.00mΩ		PRINT key pressed
7	0:00:28			200.00mΩ	Pass	.
				2.000 V		.
8	0:00:33			200.00mΩ	Pass	.
				2.000 V		.
9	0:00:38			190.00mΩ	Fail	.
				2.000 V		.
10	0:00:43			OF	Fail	.
				2.000 V		
11	0:00:49			----	Fail	
				2.000 V		
12	0:00:57			200.00mΩ	Fail	
				OF		
13	0:01:01			200.00mΩ	Fail	

END		'98-	5-	8	16:44:09	STOP key pressed

- ① Date and time at start of printing
- ② Value number (1 to 99,999)
- ③ Print time (real time or elapsed time)
- ④ Measurement value, or "OF" for overflow, "-OF" for underflow, "----" for measurement failure
- ⑤ Measurement result

When comparator not used: blank

Otherwise, comparator value: "Hi", "IN", "Lo", "Pass", or "Fail"

- ⑥ Date and time at end of printing

NOTE

- When the data print selection is set to "OFF," no values are printed.
- With the 3560, resistance values and voltage data transferred are each printed on two lines.

● **Example of printing (with the BATTERY HiTESTER)**

	②	③	①	④	
START		'96-	2-28	16:04:00	
[N]	Ω	V	°C	COMP	
1	10.23m	12.58	23.1	Pass	<p>PRINT key of the BATTERY HiTESTER pressed</p> <p>PRINT</p> <p>All the values in memory of the BATTERY HiTESTER transferred</p>
2	12.34m	12.68	23.2	Warn	
3	11.20m	11.34	23.1	Warn	
4	12.30m	12.54	22.8	Warn	
5	14.20m	10.18	23.1	Fail	
6	14.14m	13.12	23.2	Fail	
7	9.78m	12.54	23.1	Pass	
8	8.98m	12.17	23.0	Pass	
9	12.34m	12.32	23.0	Warn	
10	10.20m	11.85	22.9	Warn	
END		'96-	2-28	16:04:06	
			⑤		

- ① Date and time at start of printing
- ② Value number (1 to 260)
- ③ Measurement values (resistance, voltage and temperature measurement values), or "OF" for overflow, "-OF" for underflow, "----" for measurement failure, "----" for no temperature sensor
- ④ Measurement result
When comparator not used: blank
Otherwise, comparator value: "Pass", "Warn" (warning), or "Fail"
- ⑤ Date and time at end of printing

4.2 Ending Printing

With the m HiTESTER, when you press the **STOP** key, or when a STOP signal is input, the capture of data to memory stops.

With the BATTERY HiTESTER, after all the values in memory of the BATTERY HiTESTER are printed, printing stops.

With both the 3227 and 3550 or 3551, after printing stops, statistical processing is carried out automatically, and the results are printed.

After this, pressing the **PRINT** key again clears the data from memory, and capture of data begins again, from value number 1.

For an example of the statistics printing, see Section 5.1, "Statistical Processing."

NOTE

With the BATTERY HiTESTER, when you press the **STOP** key, or when a STOP signal is input, during printing, the previously transferred data are cleared and invalid by the new data transfer.

4.3 Cancel Function

If during printing a measurement value is captured in error, press the **CANCEL** key to cancel the value. Pressing the **CANCEL** key repeatedly steps back canceling successive values.

The maximum number of values that can be canceled (counting from the last value) is 5000 with the 3227 and 3540, and 2500 with the 3560.

```

START      '95-12-12  8:59:15
  1  0:00:00  0.5457kΩ Lo
  2  0:00:05  0.5458kΩ Lo
  3  0:00:10  0.5458kΩ Lo
  4  0:00:15  0.5458kΩ Lo
  5  0:00:20  0.5459kΩ Lo
  6  0:00:25  0.5459kΩ Lo
  7  0:00:30  0.5459kΩ Lo
  8  0:00:35  0.5460kΩ Lo
  9  0:00:40  0.5460kΩ Lo
 10  0:00:45  0.5459kΩ Lo
DATA No.   10 CANCELED
DATA No.    9 CANCELED
DATA No.    8 CANCELED
  8  0:00:50  0.5460kΩ Lo
  9  0:00:55  0.5459kΩ Lo
 10  0:01:00  0.5460kΩ Lo
END        '95-12-12  9:00:18

```

CANCEL key pressed
CANCEL key pressed
CANCEL key pressed

It is also possible to resume a printing operation by pressing the **CANCEL** key.

```

END        '95-12-12  9:00:18
STATISTICS
N          =      10    (* 10)
AVE        =  545.870 Ω
MIN        =  0.5457kΩ (  1)
MAX        =  0.5460kΩ ( 10)
σn         =  90.000mΩ
σn-1      =  94.868mΩ
Cp         =   0.86
CpK        =   0.00
CONTINUE
 11  0:01:10  0.5460kΩ Lo
 12  0:01:15  0.5460kΩ Lo
 13  0:01:20  0.5461kΩ Lo
 14  0:01:25  0.5462kΩ Lo
 15  0:01:30  0.5462kΩ Lo
 16  0:01:35  0.5462kΩ Lo
 17  0:01:40  0.5461kΩ Lo
 18  0:01:45  0.5461kΩ Lo
 19  0:01:50  0.5461kΩ Lo
 20  0:01:55  0.5461kΩ Lo

```

STOP key pressed

CANCEL key pressed

NOTE

It is not possible to cancel or resume printing the BATTERY HiTESTER values.

Chapter 5

Printing Details

5.1 Statistical Processing

After a printing operation is finished, press the **STAT** key to carry out statistical processing.

While the statistics are being printed, the following appears in the LCD.

If there are no valid values, or if the function on the tester was changed during the process, then the average value ③ and subsequent values are not printed.

With the 3560 and BATTERY HiTESTER, the multiple statistics are printed depending on the number of values transferred to the 9203 at the same time.

ON LINE
STATISTICS

STATISTICS	
① N	= 100 (* 100) ②
③ AVE	= 157.952mΩ
④ MIN	= 108.43mΩ (2) ⑤
⑥ MAX	= 207.46mΩ (71) ⑦
⑧ σ_n	= 26.547mΩ
⑧ σ_{n-1}	= 26.681mΩ
⑨ Cp	= 0.69
⑩ Cpk	= 0.65

- ① Number of values
- ② Number of valid values (excluding "OF" and "NG" results)
- ③ Average value $AVE = \sum \chi/n$
- ④ Minimum value
- ⑤ Number of minimum value (if multiple values, the latest one)
- ⑥ Maximum value
- ⑦ Number of maximum value (if multiple values, the latest one)

- ⑧ Standard deviation $\sigma_n = \sqrt{\frac{\sum \chi^2 - (\sum \chi)^2/n}{n}}$

- ⑨ Standard deviation $\sigma_{n-1} = \sqrt{\frac{\sum \chi^2 - (\sum \chi)^2/n}{n-1}}$

- ⑩ Process productivity index (dispersion)

$$C_p = \frac{|Hi - Lo|}{6\sigma_{n-1}}$$

- ⑪ Process productivity index (bias)

$$C_{pK} = \frac{|Hi - Lo| - |Hi + Lo - 2\bar{\chi}|}{6\sigma_{n-1}}$$

n the number of data values

Hi, Lo the upper and lower limit values set in the statistics setting screen

$\bar{\chi}$ the average value

If C_{pK} is negative, then C_{pK} is taken as zero.

The process productivity refers to the ability to meet quality standards, and indicates the variance of the process quality.

Generally, the process productivity can be assessed from the values C_p and C_{pK} as follows:

$C_p, C_{pK} > 1.33$	process productivity is ample
$1.33 > C_p, C_{pK} > 1.00$	process productivity is adequate
$1.00 > C_p, C_{pK}$	process productivity is inadequate

NOTE

- If there are no valid values, or if the function on the tester was changed during the process, then the average value ③ and subsequent values are not printed.
- If there is exactly one valid value, then the standard deviation σ_{n-1} ⑨ and subsequent values are not printed.
- If the maximum or minimum value in the data has been canceled, it is printed as "INVALID".
- If σ_{n-1} is zero, Cp and CpK are printed as "INVALID".
- If multiple items of measurement data are transferred at the same time, items from the second one onward are printed without Cp or CpK.

5.2 Histograms

After a printing operation is finished, press the **HIST** key to create a histogram.

The histogram is created according to the settings in the histogram setting screen.

While the histogram is being printed, the following appears in the LCD. The number indicates the number of data values remaining to be processed.

With the 3560 and BATTERY HiTESTER, the multiple histograms are printed depending on the number of values transferred to the 9203 at the same time.

The image shows a rectangular LCD display with a black border. Inside, the word "HISTOGRAM" is printed in a large, bold, pixelated font at the top. Below it, "N= 3520" is printed in a similar pixelated font. A thin vertical line extends from the bottom of the "0" in "3520" down to the text "Number of remaining values" below the display.

Number of remaining values

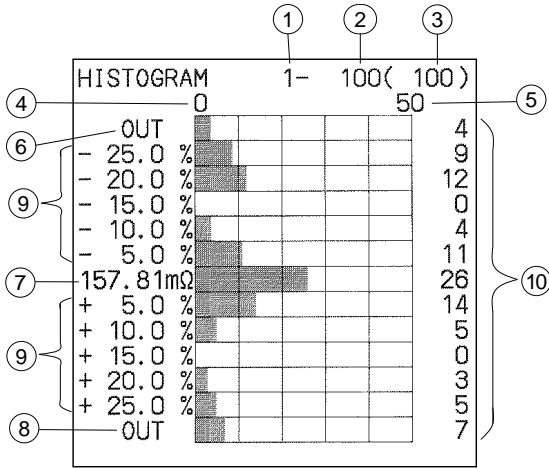

- ① Number of first value
- ② Number of last value
- ③ Number of values
- ④ Count (minimum value)
- ⑤ Count (maximum value)
- ⑥ Values below lower limit of range
- ⑦ Center value
- ⑧ Values above upper limit of range
- ⑨ Center values of each rank
- ⑩ Count of values in each rank

Measurement data values are assigned to a rank by the following comparison:

$$(\text{rank minimum}) < (\text{rank maximum})$$

Here the rank minimum and maximum values are derived as follows:

$$(\text{rank minimum}) = (\text{center value}) \times \{1 + [(\text{rank center value}) - (\text{rank width})/2] / 100\}$$

$$(\text{rank maximum}) = (\text{center value}) \times \{1 + [(\text{rank center value}) + (\text{rank width})/2] / 100\}$$

NOTE

- The maximum number of data points that can be printed in one histogram is 5000 with the 3227 and 3540, and 2,500 with the 3560. If the maximum number of points is exceeded, the most recent points up to the maximum are used.
- If no data is present, or if the function on the tester was changed during the process, then no histogram is created. Again, in auto mode if there is no valid data, no histogram is created.
- If multiple items of measurement data are transferred at the same time, the histograms of items from the second one onward are always created in auto mode.

5.3 Graphs

After a printing operation is finished, press the **■** **PLOT** **■** key to print a graph of the measurement values.

While the graph is being plotted, the following appears in the LCD.

With the 3560 and BATTERY HiTESTER, the multiple graphs are printed depending on the number of values transferred to the 9203 at the same time.

A rectangular LCD display showing the text 'ON LINE' on the left and 'PLOT' on the right, both in a pixelated font.

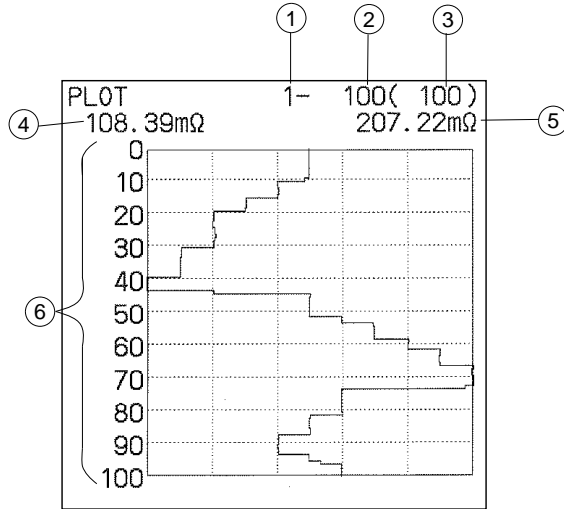

- ① Number of first value
- ② Number of last value
- ③ Number of values
- ④ Measurement value (minimum value)
- ⑤ Measurement value (maximum value)
- ⑥ Value numbers

On the measurement axis of the graph, the minimum and maximum valid data values in memory are used as the limits of the full-scale range, and the values are plotted evenly spaced by value number.

NOTE

- The maximum number of data points that can be printed in one graph is 5000 with the 3227 and 3540, and 2,500 with the 3560. If the maximum number of points is exceeded, the most recent points up to the maximum are used.
- If no data is present, or if the function on the tester was changed during the process, then no graph is plotted.

Chapter 6

Other Functions

6.1 System Reset

Power on the product while holding down the \triangle and ∇ keys simultaneously to reset the product.

At this point the following appears in the LCD.

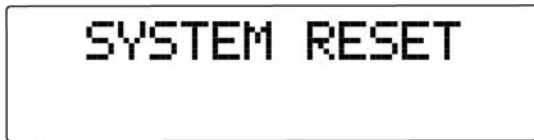

This carries out a system reset, which returns all the settings of the product to their factory default values.

	Item	Factory default setting
Print settings	Data print selection	ALL
	Print interval	MANU
	Print time	REAL
Statistics settings	Upper limit	000.00m
	Lower limit	000.00m
Histogram settings	Creation mode	AUTO
	Center value	000.00m
	Rank width	0.1% (± 5)

6.2 Error Indications

If any sort of error is detected in the product, this is shown in the LCD display. Either after the error is cleared, or after displaying for about one second, the display returns to the previous indication.



HEAD UP

Indication	Problem	Follow-up
ROM ERROR	An error has occurred in the ROM.	The fault must be repaired.
RAM ERROR	An error has occurred in the RAM.	The fault must be repaired.
HEAD UP	The printer head is up.	Lower the printer head.
PAPER END	There is no recording paper.	Reload the recording paper.
MISS CONNECT	Either nothing is connected to this product, or there is an error in the interface connection.	Check the interface connection.
NO DATA	There is no captured data in memory.	Capture data before proceeding.
FUNCTION CHANGE	During capture of data, the function (units) on the tester was changed.	During capture of data, do not change the function on the tester.
CAN NOT CANCEL	Attempted to cancel BATTERY HiTESTER data.	BATTERY HiTESTER data cannot be canceled.

NOTE

If a HEAD UP or PAPER END error occurs during printing, after the error is cleared printing resumes.

Chapter 7

External I/O Terminals

7.1 Terminals

- (1) Use appropriate wires, with about 10 mm of the insulation stripped.
- (2) As shown in the figure, push in the terminal button with a screwdriver or similar implement, and insert the wire into the terminal aperture.
- (3) After inserting the wire, release the button to lock the wire in place.
- (4) To disconnect a wire, use a similar procedure.

To avoid electric shock, use the recommended wire type to connect to the current input terminals, or otherwise ensure that the wire used has sufficient current handling capacity and insulation.

Recommended wire:

Single strand 1.0 mm dia. (AWG #18)

Multi-strand 0.75 mm²

Usable limits:

Single strand 0.4 to 1.0 mm dia. (AWG #26 to #18)

Multi-strand 0.3 to 0.75 mm² (AWG #22 to #20)

Strand diameter minimum 0.18 mm

Standard insulation stripping length: 10 mm

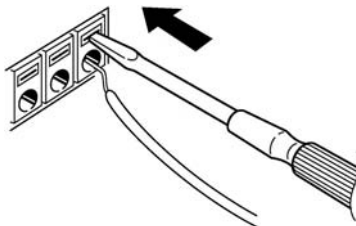

7.2 Ground Terminal

The GND terminal is a common ground terminal for all external I/O.

7.3 Output Terminals

These are open collector outputs.

The transistors are turned on when the following signals are effective.

TRIG A print trigger is output. Connect to the m HiTESTER.

ERROR When there is a fault in the printer, this signal is output.



To avoid damage to the product, do not input voltage to the output terminals.

NOTE

The open collector outputs are rated at 35 V, 50 mA maximum. If using a relay, connect a diode to eliminate any generated back e.m.f.

7.4 Input Terminals

These are TTL negative logic inputs (rating: 5 V maximum).

To make the following signals effective, short to ground.

PRINT External input terminal for a print command signal. (Same effect as pressing the **PRINT** key.)

STOP External input terminal for a stop command signal. (Same effect as pressing the **STOP** key.)



To avoid damage to the product, do not input a voltage or current exceeding the specified rating to the external input terminals.

Chapter 8 Specifications

Printer	Thermal line printer
Print medium	9233 recording paper, 58 mm × 10 m (approximately 3000 lines equivalent)
Lifetime	At least 2 million lines
Display	Character LCD module
Display digits	16 digits × 2 lines
Clock	Built-in clock/calendar
Printing items	Measurement data, computation data, histogram, graph of the measurement values
Data handling capacity	1 to 99999 values (histogram, graph of the measurement values: most recent 5000 values* ⁷ are used)
Interface	Centronics

External output terminals (open collector outputs)

TRIG	Print trigger output
ERROR	Error output

External input terminals (TTL negative logic inputs)

PRINT	Print command input
STOP	Stop command input

Dielectric strength	1.5 kVAC (perceptible current: 20 mA) between case and power supply line
Insulation resistance	100 M min. between case and power supply line
Operating temperature and humidity range	0 to 40 (32°F to 104°F), 80% RH max. (no condensation)
Storage temperature and humidity range	-10 to 50 (14°F to 122°F), 80% RH max. (no condensation)
Operating height	2000 m max. (6562-ft.)
Power supply	Rated power voltage 100 to 240 VAC (Voltage fluctuations of \pm 10% from the rated supply voltage are taken into account.) Rated power frequency 50/60 Hz
Maximum rated power	30 VA
Dimensions	Approx. 215 (W) \times 160 (H) \times 54 (D) mm (excluding projections) 8.46"W \times 6.3"H \times 2.13"D
Mass	Approx. 1.1 kg (38.8 oz)
Standards applying	EMC EN61326, EN61000-3-2, EN61000-3-3 Safety EN61010 Pollution Degree 2
Replacement part	Fuse (T4.0AL/250 V 20 mm \times 5 mm dia.)

Supplied accessories	Power cord, spare fuse (T4.0AL/250 V 20 mm × 5 mm dia.), recording paper (1 roll), connection leads for m HiTESTER (2 × 2 m)
Options	9425 CONNECTION CABLE 9233 RECORDING PAPER (10 rolls)

Printed data

Maximum number of printed values* ¹	99,999 (After 99,999 values are printed, computation processing is carried out automatically, then the operation terminates.)
Data print selection* ²	ALL Print all values IN Print all "IN" values HL Print all "Hi" or "Lo" values VAL Print all valid values OFF No printing
Printed result codes	Hi/IN/Lo/Pass/Warn/Fail/OF/-OF/NG
Printing interval setting* ²	MANU (manual)/AUTO AUTO interval settings 1/2/5/10/15/20/30 seconds, 1/2/5/10/15/20/30 minutes, 1 hour In auto mode, manual printing also possible.
Time printing* ²	hh:mm:ss (real time or elapsed time printing)
Cancel function* ³	Immediately previous data values can be deleted (with the m HiTESTER, up to maximum 5000 values* ⁷)

Computation functions*⁴

Data handling capacity 99,999 values

Functions computed number of values, maximum, minimum and average values, standard deviation, process productivity index*⁵ (dispersion and bias) (from upper and lower limit settings)

Histogram printing*⁴

Data handling capacity 5000 values*⁷ (if more than 5000 present, most recent 5000 values are used)

Operation mode Auto*⁶/manual
 Manual center value setting:
 5-digit signed value, plus unit prefix 'm', none, or 'k'
 Manual rank width setting:
 0.1/0.2/0.5/1/2/5/10/20 % (± 5 ranks)
 0.1/0.2/0.5/1/2/5/10 % (± 10 ranks)
 AUTO setting: Center value and rank width set automatically

Graph printing*⁴

Data handling capacity 5000 values*⁷ (if more than 5000 present, most recent 5000 values are used)

Operation mode Auto only
 Measurement axis scale determined automatically
 Values are plotted evenly spaced by value number.

- *1 With the BATTERY HiTESTER, the maximum number of printed values is 260.
- *2 With the BATTERY HiTESTER, these settings are ignored.
- *3 With the BATTERY HiTESTER , the cancel function is invalid.
- *4 The multiple computations, histograms and graphs are printed depending on the number of values transferred at the same time.
- *5 Values from the second one onward are computed without the process productivity index depending on the number of values transferred at the same time.
- *6 The histograms of values from the second one onward are always created in auto mode depending on the number of values transferred at the same time.
- *7 With the 3560, 2500 values



Chapter 9

Maintenance and Servicing

9.1 Power Fuse Replacement

The power fuse is contained in the power inlet compartment, together with a spare fuse. Use the following procedure to replace the fuse.

WARNING

To avoid electric shock, turn off the power switch and disconnect the power cord before replacing the fuse.

- (1) After removing the power cord from the inlet, use a flat screwdriver or similar instrument to pull out the fuse holder as shown in the following figure.

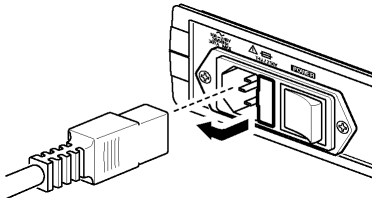



(2) Check the fuse, then replace it with the spare.

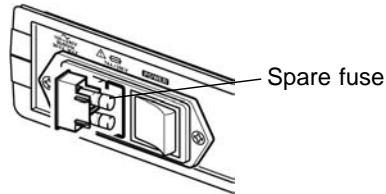

(3) Push the fuse holder back into the power inlet to complete the procedure.

WARNING

Replace the fuse only with one of the specified characteristics and voltage and current ratings. Using a non-specified fuse or shorting the fuse holder may cause a life-threatening hazard.

Fuse type: T4.0AL/250 V 20 mm × 5 mm dia.

9.2 Ultimate Disposal

The product includes a lithium battery which provides a backup power supply for the settings in memory. When disposing of this product, remove the lithium battery and dispose of battery and product in accordance with local regulations.

⚠WARNING

- **To avoid electrocution, turn off the power switch and disconnect the power cord before removing the lithium battery.**
- **Handle and dispose of batteries in accordance with local regulations.**

NOTE

If the protective functions of the product are damaged, either remove it from service or mark it clearly so that others do not use it inadvertently.

● Tools required for disassembly

The following tools are required for disassembling the product:

- Phillips screwdriver
- Miniature pliers (or nippers)

● Disassembly procedure

- (1) Remove the two screws fastening the case of the product as shown in the figure below.
- (2) Lift the upper case vertically to remove it.
- (3) Use the pliers to wrench the lithium battery from the PCB on which it is mounted.

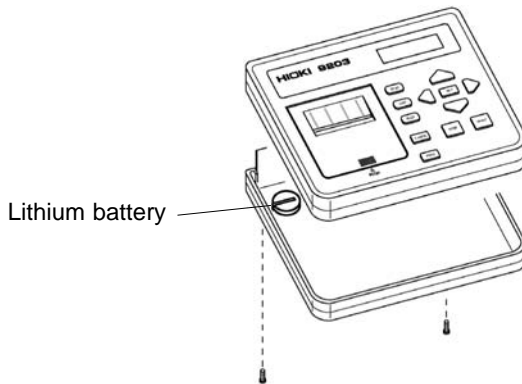

CALIFORNIA, USA ONLY

This product contains a CR Coin Lithium Battery which contains Perchlorate Material - special handling may apply.

See www.dtsc.ca.gov/hazardouswaste/perchlorate

Index

- A -**
- Average value 34
- C -**
- Cancel function 31
Center value 23, 24
CONNECTION CABLE 9, 11
Connection leads 9, 11
Contrast (display) 10, 17
Creation mode 24
- D -**
- Data print selection 20
- E -**
- Ending printing 31
Error indications 40
External I/O terminals 9, 41
- G -**
- Graph of the measurement values 37
- H -**
- Histogram setting screen 19, 23, 25
Histogram 23, 35
- I -**
- Interval 21, 28
- L -**
- Lithium battery 53, 54
- M -**
- Maximum value 34
Menu screen 19, 25
Minimum value 34
- P -**
- Power fuse 9, 51
Print setting screen 19, 20, 25
PRINTER INTERFACE 11
Process productivity index 22, 34
- R -**
- Rank width 23, 24
Recording paper 5, 14
- S -**
- Self-test 16
Standard deviation 34
Starting printing 27
Statistical processing 31, 33
Statistics setting screen 19, 22, 25
System reset 39
- T -**
- Time printed 21
Time setting screen 19, 25

HIOKI

HIOKI E. E. CORPORATION

Headquarters

81 Koizumi, Ueda, Nagano 386-1192, Japan
TEL +81-268-28-0562 FAX +81-268-28-0568 E-mail: os-com@hioki.co.jp
URL <http://www.hioki.com/>
(International Sales and Marketing Department)

HIOKI USA CORPORATION

6 Corporate Drive, Cranbury, NJ 08512, USA
TEL +1-609-409-9109 FAX +1-609-409-9108 E-mail: hioki@hiokiusa.com
URL <http://www.hiokiusa.com>

HIOKI (Shanghai) Sales & Trading Co., Ltd.

1608-1610, Shanghai Times Square Office 93 Huaihai Zhong Road Shanghai,
P.R.China POSTCODE: 200021
TEL +86-21-63910090 FAX +86-21-63910360 E-mail: info@hioki.com.cn
URL <http://www.hioki.cn>

HIOKI INDIA PRIVATE LIMITED

Khandela House, 24 Gulmohar Colony Indore 452 018 (M.P.), India
TEL +91-731-6548081 FAX +91-731-4020083 E-mail: info@hioki.in
URL <http://www.hioki.in>

HIOKI SINGAPORE PTE. LTD.

33 Ubi Avenue 3, #03-02 Vertex Singapore 408868
TEL +65-6634-7677 FAX +65-6634-7477 E-mail: info@hioki.com.sg 1205

-
- For regional contact information, please go to our website at <http://www.hioki.com>.
 - The Declaration of Conformity for instruments that comply to CE mark requirements may be downloaded from the HIOKI website.
 - All reasonable care has been taken in the production of this manual, but if you find any points which are unclear or in error, please contact your supplier or the International Sales and Marketing Department at Hioki headquarters.
 - In the interests of product development, the contents of this manual are subject to revision without prior notice.
 - The content of this manual is protected by copyright. No reproduction, duplication or modification of the content is permitted without the authorization of Hioki E.E. Corporation.